



DESCRIPTION

Be compatible with 19-inch equipment rack, cabinets, and wall mount shelf, suitable for interaction and termination of horizontal cabling between devices, equipment and centralized points.

APPLICATION

- Unique exterior design, simple, compact and beautiful
- Accomplish a clean and beautiful cabling system with simple, flexible, effective, convenient and safe feature
- Black appearance enables its combination of any other equipment in data center

PRODUCT DIMENSIONS

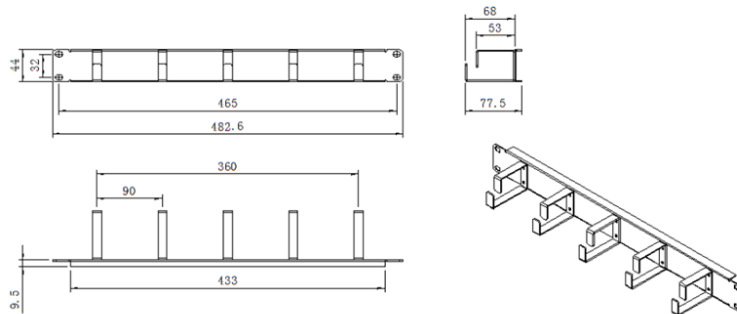

ORDERING INFORMATION

Product code	Description	Color	Inner Box	Carton	Carton measurement (L*W*H)	Weight
9-2009106	Black panel cable management 1U	Black	1 pc.	10 pcs.	53 cm × 31 cm × 23 cm	3.8 kg