

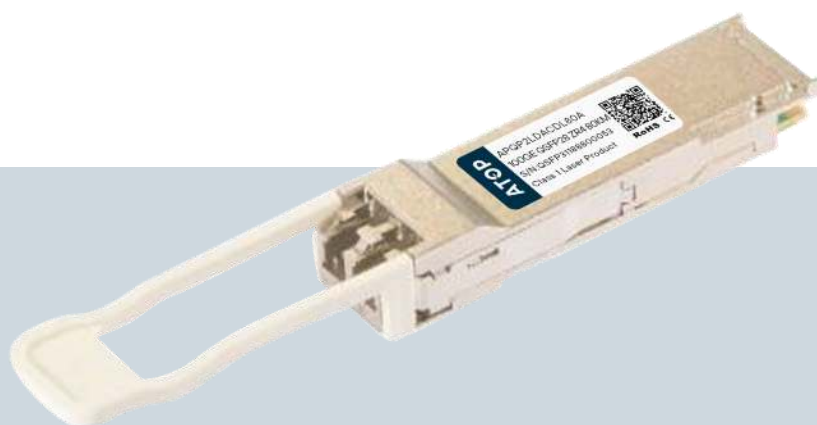

# 100GE QSFP28 ZR4 Transceiver

APQP2LDACDL80A



# 100GE QSFP28 ZR4 Transceiver

APQP2LDACDL80A

## Product Features

- ✓ QSFP28 MSA compliant
- ✓ Hot pluggable 38 pin electrical interface
- ✓ 4 LAN-WDM lanes MUX/DEMUX design
- ✓ 4x25G electrical interface
- ✓ EML laser and PIN+SOA receiver
- ✓ Maximum power consumption 6.5W
- ✓ LC duplex connector
- ✓ Supports 103.125Gb/s aggregate bit rate
- ✓ Up to 80km transmission on single mode fiber
- ✓ Operating case temperature: 0°C to 70°C
- ✓ Single 3.3V power supply
- ✓ RoHS 2.0 compliant

## Applications

- ✓ 100GBASE-ZR4 100G Ethernet
- ✓ Telecom networking



## Product Selection

Part Number	Operating Case temperature	DDMI
APQP2LDACDL80A	Commercial(0~70°C)	Yes

## Regulatory Compliance

- ESD to the Electrical PINs: compatible with MIL-STD-883 Method 3015
- ESD to the Duplex LC Receptacle: compatible with IEC 61000-4-2
- Immunity compatible with IEC 61000-4-3
- EMI compatible with FCC Part 15 Class B EN55022 Class B (CISPR 22B) VCCI Class B
- Laser Eye Safety compatible with FDA 21CFR 1040.10 and 1040.11 EN60950, EN (IEC) 60825-1,2

## Pin Descriptions

Pin	Symbol	Name	Ref.
1	GND	Ground	1
2	Tx2n	Transmitter Inverted Data Input	
3	Tx2p	Transmitter Non-Inverted Data input	
4	GND	Ground	1
5	Tx4n	Transmitter Inverted Data Input	
6	Tx4p	Transmitter Non-Inverted Data Input	
7	GND	Ground	1
8	ModSelL	Module Select	
9	ResetL	Module Reset	
10	VccRx	+ 3.3V Power Supply Receiver	
11	SCL	2-Wire Serial Interface Clock	
12	SDA	2-Wire Serial Interface Data	
13	GND	Ground	1
14	Rx3p	Receiver Non-Inverted Data Output	
15	Rx3n	Receiver Inverted Data Output	
16	GND	Ground	1
17	Rx1p	Receiver Non-Inverted Data Output	
18	Rx1n	Receiver Inverted Data Output	
19	GND	Ground	1
20	GND	Ground	1
21	Rx2n	Receiver Inverted Data Output	
22	Rx2p	Receiver Non-Inverted Data Output	
23	GND	Ground	1
24	Rx4n	Receiver Non-Inverted Data Output	
25	Rx4p	Receiver Inverted Data Output	
26	GND	Ground	1
27	ModPrsL	Module Present	
28	IntL	Interrupt	
29	VccTx	+3.3 V Power Supply transmitter	
30	Vcc1	+3.3 V Power Supply	
31	LPMode	Low Power Mode	
32	GND	Ground	1
33	Tx3p	Transmitter Non-Inverted Data Input	
34	Tx3n	Transmitter Inverted Data Input	

Pin	Symbol	Name	Ref.
35	GND	Ground	1
36	Tx1p	Transmitter Non-Inverted Data Input	
37	Tx1n	Transmitter Inverted Data input	
38	GND	Ground	1

Notes:

1. Circuit ground is internally isolated from chassis ground.

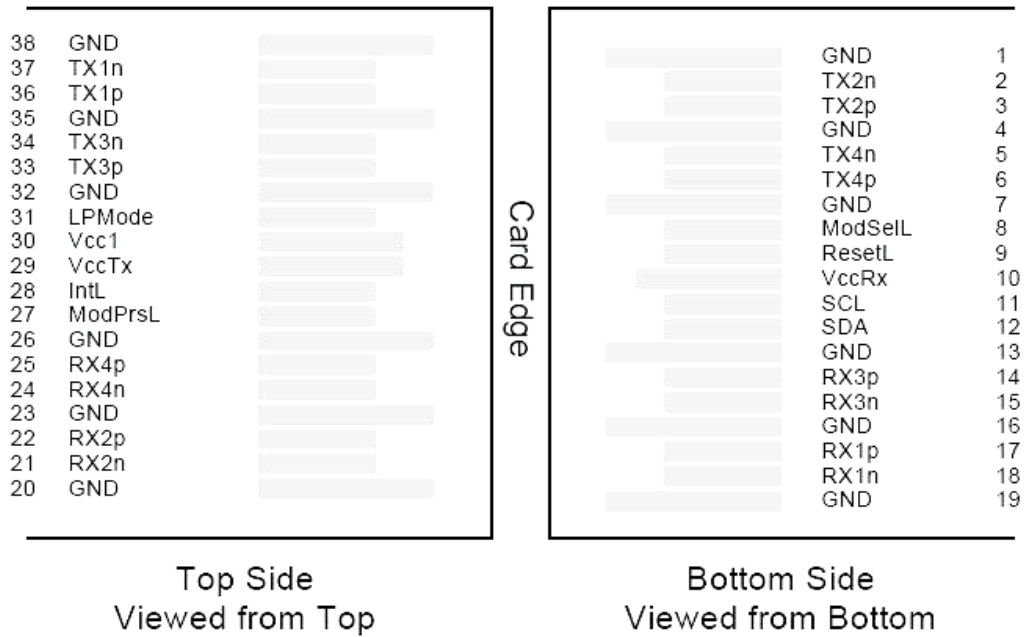

Pin-out of Connector Block on Host Board

## Transceiver Block Diagrams

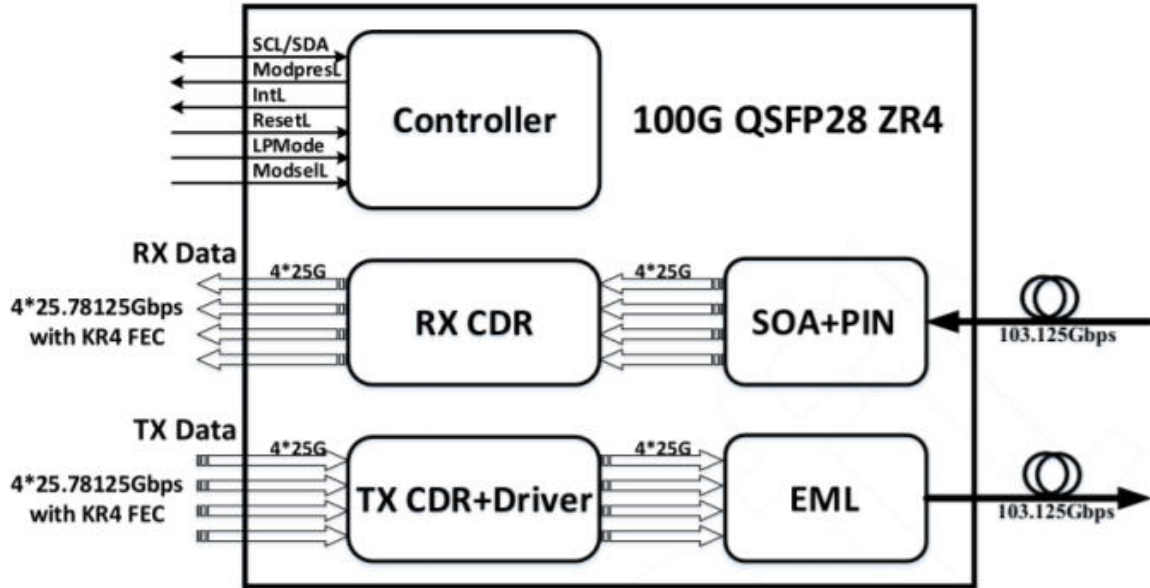

## Absolute Maximum Ratings

Parameter	Symbol	Min	Typ	Max	Unit	Ref.
Maximum Supply Voltage	Vcc	0		+3.6	V	
Storage Temperature	TS	-40		+85	°C	
Operating Humidity	RH	0		85	%	

## Recommended Operating Conditions

Parameter	Symbol	Min	Typ	Max	Unit	Ref.
Power Supply Voltage	Vcc	3.13	3.30	3.47	V	
Power Supply Current	Icc			1.8759	A	
Power dissipation				6.5	W	
Case Operating Temperature	Tc	0		+70	°C	Commercial
9/125um G.652 SMF	Lmax			80	km	

## Electrical Characteristics

Parameter	Symbol	Min	Typ	Max	Unit	Ref.
<b>Transmitter</b>						
Data Rate, each lane			25.78125		Gbps	
Differential Voltage pk-pk	Vpp			900	mV	1
Common Mode Voltage	Vcm	-350		2850	mV	
Transition time	Trise/Tfall	10			ps	2
Differential Termination Resistance Mismatch				10	%	
Eye width	EW15	0.46			UI	
Eye height	EH15	95			mV	
<b>Receiver</b>						
Data Rate, each lane			25.78125		Gbps	
Differential Termination Resistance Mismatch				10	%	1
Differential output voltage swing	Vout, pp			900	mV	
Common Mode Noise, RMS	Vrms			17.5	mV	
Transition time	Trise/Tfall	12			ps	2
Eye width	EW15	0.57			UI	
Eye height	EH15	228			mV	

Notes:

1. At 1 MHz.
2. 20%~80%.

## Optical Characteristics

Parameter	Symbol	Min	Typ	Max	Unit	Ref.
<b>Transmitter</b>						
Signaling Speed per Lane			25.78125 ± 100 ppm		Gb/s	
Optical Wavelength	L0	1294.53		1296.59	nm	
	L1	1299.02		1301.09	nm	
	L2	1303.54		1305.63	nm	
	L3	1308.09		1310.19	nm	
Side-Mode Suppression Ratio	SMSR	30			dB	
Total Average Launch Power		8		12.5	dBm	
Average launch power, each lane		2		6.5	dBm	

Difference in launch power between any two lanes(Average and OMA)		3	dBm	
Average launch power of OFF transmitter, each lane		-30	dBm	
Extinction Ratio	ER	6	dB	
RIN OMA		-130	dB/Hz	
Optical return loss tolerance		20	dB	
Transmitter reflectance		-12	dB	
Transmitter eye mask definition {X1,X2, X3, Y1, Y2, Y3}		{0.25, 0.4, 0.45, 0.25, 0.28, 0.4}		1
Mask margin		5	%	
<b>Receiver</b>				
Signaling Speed per Lane		25.78125 ± 100 ppm	Gb/s	
Receive wavelengths	L0	1294.53	1296.59	nm
	L1	1299.02	1301.09	nm
	L2	1303.54	1305.63	nm
	L3	1308.09	1310.19	nm
Average receiver power, each lane		-28	-7	dBm
Receiver power, each lane (OMA)		-7	dBm	
Receiver reflectance		-26	dB	
Receiver sensitivity Average, each lane		-28	dBm	1
Receiver 3 dB electrical upper cutoff frequency, each lane		31	GHz	
Damage threshold, each lane		6.5	dBm	
LOS De-Assert	LOSD	-29	dBm	
LOS Assert	LOSA	-40	dBm	
LOS Hysteresis		0.5	dB	

## Notes:

1. Sensitivity is specified at BER@5E-5 with FEC

### Mechanical Specifications

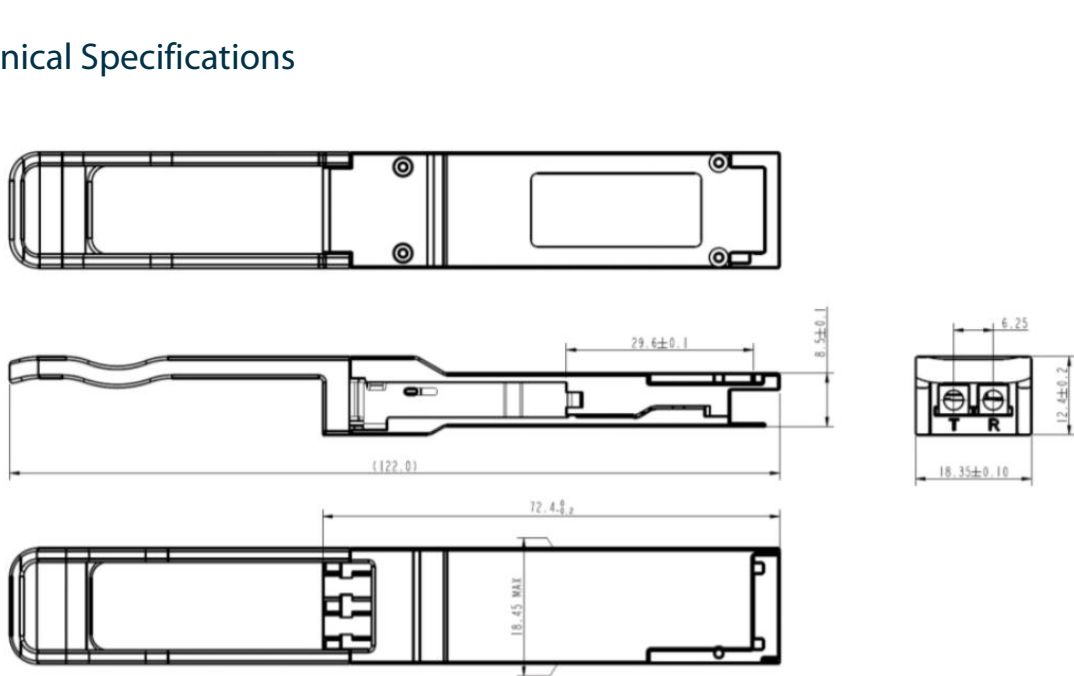

APQP2LDACDL80A



## EEPROM Information

- EEPROM memory map specific data field description is as below:

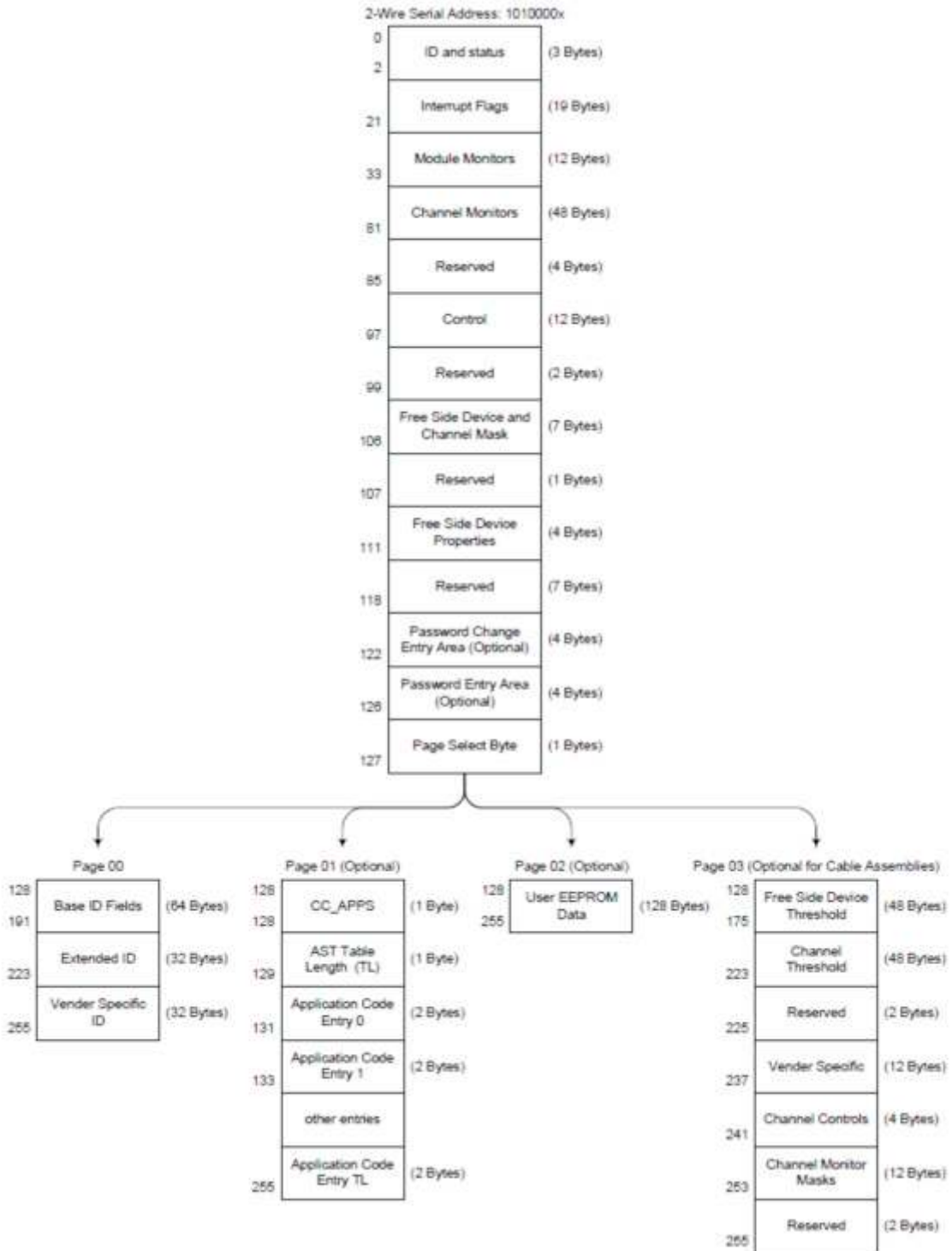

## Digital Diagnostic Monitoring Interface

Five transceiver parameter values are monitored. The following table defines the Monitor parameter's accuracy.

Parameter	Related Bytes(A0[00] memory)	Accuracy	Notes
Temperature	22 to 23	±3°C	1,2
Voltage	26 to 27	<3%	2
Bias Current	42 to 49	<10%	2
TX Power	50 to 57	<3dB	2
RX Power	34 to 41	<3dB	2

**Notes:**

1. Actual temperature test point is fixed on module case around Laser.
2. Full operating temperature range.

## Revision History

Revision	Initiated	Reviewed	Approved	DCN	Release Date
Version1.0	Tang Rong	Billy Tang	Yuan Wei	New Released.	Feb 25, 2021
Version1.1	Tang Rong	Billy Tang	Yuan Wei	1.Update the new template . 2.Update Digital Diagnostic Monitoring Interface. 3.Update EEPROM Information.	Apr 25, 2021



let's make it personal