



## 1.25Gb/s SFP Transceiver

### APS55123CDLB6

#### ■ Product Features

- ✓ Up to 1.25Gb/s data links
- ✓ Duplex LC connector
- ✓ Hot-pluggable SFP footprint
- ✓ 1550nm DFB laser transmitter
- ✓ RoHS compliant and Lead Free
- ✓ Up to 160Km on 9/125um SMF
- ✓ Metal enclosure for lower EMI
- ✓ Single +3.3V power supply
- ✓ Power dissipation <1W
- ✓ Commercial operating temperature optional
- ✓ SFP MSA SFF-8074i Compliant



#### ■ Applications

- ✓ Gigabit Ethernet
- ✓ 1x Fibre Channel

#### ■ General

ATOP's APS55123CDLB6 Small Form Factor Pluggable (SFP) transceivers are compatible with the Small Form Factor Pluggable Multi-Sourcing Agreement (MSA). The SFP transceivers are high performance, cost effective modules supporting dual data-rate of 1.25Gbps/1.063Gbps and 160km transmission distance with SMF. They are RoHS compliant and lead-free.

#### ■ Product Selection

Part Number	Operating temperature	DDMI
APS55123CDLB6	Commercial	Yes

#### ■ Regulatory Compliance

- ESD to the Electrical PINs: compatible with MIL-STD-883 Method 3015
- ESD to the Duplex LC Receptacle: compatible with IEC 61000-4-2
- Immunity compatible with IEC 61000-4-3



- EMI compatible with FCC Part 15 Class B EN55022 Class B (CISPR 22B) VCCI Class B
- Laser Eye Safety compatible with FDA 21CFR 1040.10 and 1040.11 EN60950, EN (IEC) 60825-1,2
- RoHS compliant with RoHS 2 (2011/65/EU)

**Pin Descriptions**

Pin	Symbol	Name/Description	Ref.
1	VeeT	Transmitter Ground (Common with Receiver Ground)	1
2	TX Fault	Transmitter Fault.	
3	TX Disable	Transmitter Disable. Laser output disabled on high or open.	2
4	MOD_DEF(2)	Module Definition 2. Data line for Serial ID.	3
5	MOD_DEF(1)	Module Definition 1. Clock line for Serial ID.	3
6	MOD_DEF(0)	Module Definition 0. Grounded within the module.	3
7	Rate Select	No connection required	
8	LOS	Loss of Signal indication. Logic 0 indicates normal operation.	4
9	VeeR	Receiver Ground (Common with Transmitter Ground)	1
10	VeeR	Receiver Ground (Common with Transmitter Ground)	1
11	VeeR	Receiver Ground (Common with Transmitter Ground)	1
12	RD-	Receiver Inverted DATA out. AC Coupled	
13	RD+	Receiver Non-inverted DATA out. AC Coupled	
14	VeeR	Receiver Ground (Common with Transmitter Ground)	1
15	VccR	Receiver Power Supply	
16	VccT	Transmitter Power Supply	
17	VeeT	Transmitter Ground (Common with Receiver Ground)	1
18	TD+	Transmitter Non-Inverted DATA in. AC Coupled.	
19	TD-	Transmitter Inverted DATA in. AC Coupled.	
20	VeeT	Transmitter Ground (Common with Receiver Ground)	1

**Notes:**

1. Circuit ground is internally isolated from chassis ground.
2. Laser output disabled on TX Disable >2.0V or open, enabled on TX Disable <0.8V.
3. Should be pulled up with 4.7k - 10kohms on host board to a voltage between 2.0V and 3.6V.

MOD\_DEF (0) pulls line low to indicate module is plugged in.

- LOS is open collector output. Should be pulled up with 4.7k – 10kohms on host board to a voltage between 2.0V and 3.6V. Logic 0 indicates normal operation; logic 1 indicates loss of signal.

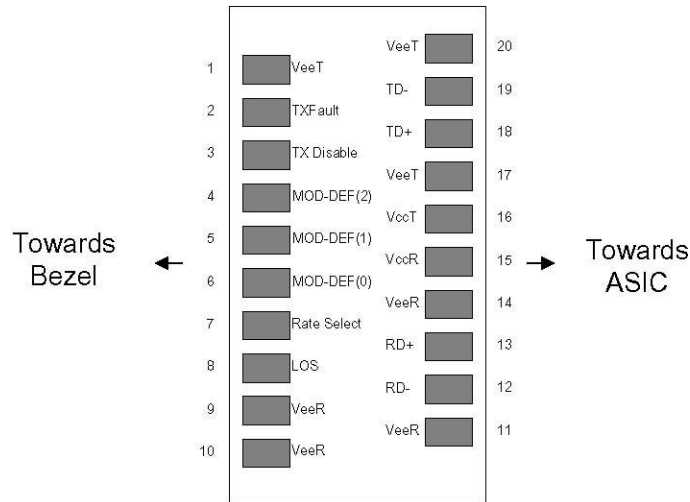

**Pin-out of Connector Block on Host Board**

■ **Recommend Circuit Schematic**

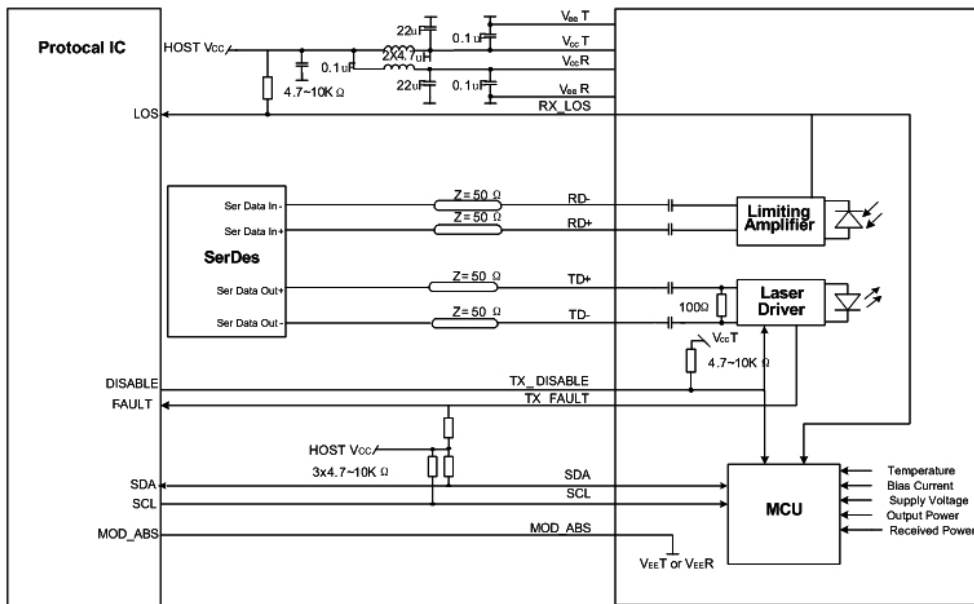

■ **Absolute Maximum Ratings**

Parameter	Symbol	Min	Typ	Max	Unit	Ref.
Maximum Supply Voltage	Vcc	-0.5		+4.0	V	
Storage Temperature	TS	-40		+85	°C	



Operating Humidity	RH	0		85	%	
--------------------	----	---	--	----	---	--

■ **Recommended Operating Conditions**

Parameter	Symbol	Min	Typ	Max	Unit	Ref.
Power Supply Voltage	Vcc	3.13	3.30	3.47	V	
Power Supply Current	Icc			300	mA	
Case Operating Temperature	T	0		+70	°C	
Data Rate(Gigabit Ethernet)			1.25		Gbps	
Data Rate(Fibre Channel)			1.063		Gbps	
9/125um G.652 SMF	Lmax			160	km	

■ **Electrical Characteristics (TOP=25°C, Vcc=3.3Volts)**

Parameter	Symbol	Min	Typ	Max	Unit	Ref.
<b>Transmitter</b>						
Input differential impedance	Rin	-	100	-	Ω	1
Single ended data input swing	Vin, pp	250	-	1200	mV	
TX Disable-High	-	Vcc – 1.3	-	Vcc	V	
TX Disable-Low	-	Vee	-	Vee+ 0.8	V	
TX Fault-High	-	Vcc-0.5	-	Vcc	V	
TX Fault-Low	-	Vee	-	Vee+0.5	V	
<b>Receiver</b>						
Single ended data output swing	Vout, pp	300	400	800	mV	2
Data output rise time	tr	-	-	175	ps	3
Data output fall time	tf	-	-	175	ps	3
LOS-High	-	Vcc – 0.5	-	Vcc	V	
LOS-Low	-	Vee	-	Vee+0.5	V	

**Notes:**

1. AC coupled.
2. Into 100 ohm differential termination.
3. 20 – 80 %



■ **Optical Characteristics (TOP=25°C, Vcc=3.3 Volts)**

Parameter	Symbol	Min	Typ	Max	Unit	Ref.
<b>Transmitter</b>						
Output Opt. Power	PO	+2	-	+7	dBm	1
Optical Wavelength	$\lambda$	1530	1550	1570	nm	
Spectral Width(-20dB)	$\Delta \lambda$	-	-	1	nm	
Side Mode Suppression Ratio	SMSR	30	-	-	dB	
Optical Rise/Fall Time	tr/tf	-	-	260	ps	2
Total Jitter	TJ	-	-	0.35	UI	
Optical Extinction Ratio	ER	9	-	-	dB	
<b>Receiver</b>						
RX Sensitivity @1.25Gb/s	SENS	-	-	-33	dBm	3, 4
Receiver Overload	-	-9	-	-	dBm	
Optical Center Wavelength	$\lambda_C$	1270	-	1600	nm	
LOS De-Assert	LOSD	-	-	-34	dBm	
LOS Assert	LOSA	-45	-	-	dBm	
LOS Hysteresis	-	0.5	-	5	dB	

**Notes:**

1. Class 1 Laser Safety.
2. Unfiltered, 20-80%. Complies with GE and 1x FC eye masks when filtered.
3. Measured with conformance signals defined in FC-PI-2 Rev. 10.0 specifications.
4. Measured with PRBS  $2^7-1$  at  $10^{-12}$  BER.

■ **Mechanical Specifications**

ATOP's Small Form Factor Pluggable (SFP) transceivers are compatible with the dimensions defined by the SFP Multi-Sourcing Agreement (MSA).

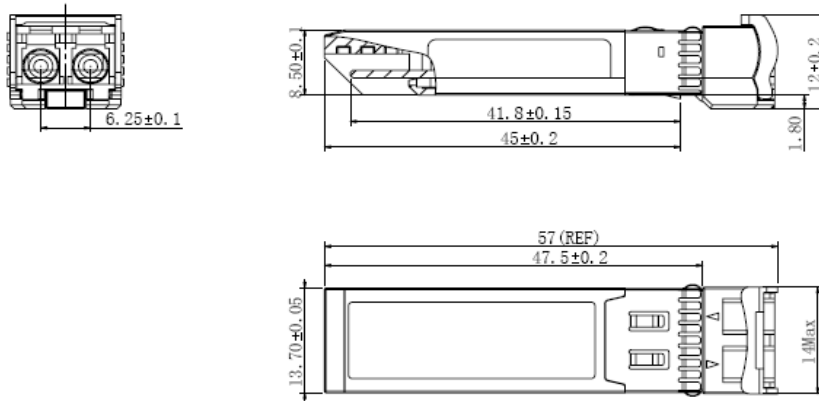

**APS55123CDLB6**

■ **EEPROM Information**

EEPROM memory map specific data field description is as below:

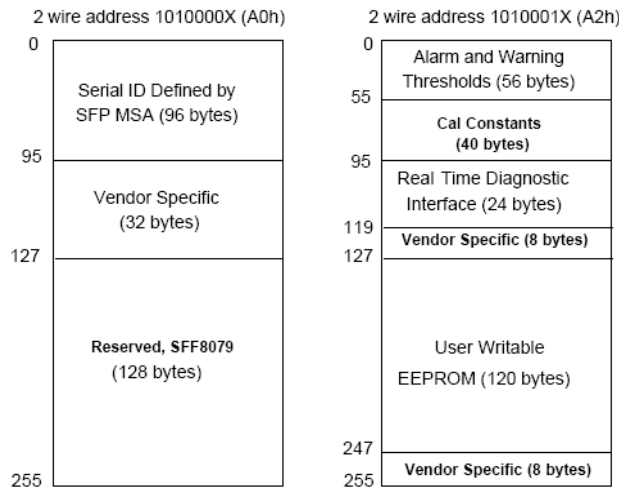

■ **Digital Diagnostic Monitoring Interface**

Five transceiver parameter values are monitored. The following table defines the monitored parameter's accuracy.

Parameter	Range	Accuracy	Calibration
Temperature	0 to +70°C	±3°C	Internal
Voltage	2.97 to 3.63V	±3%	Internal



Connects fiber to your home

**ATOP Corporation**

1.25Gb/s SFP Transceiver

## **APS55123CDLB6**

Bias Current	0 to 100mA	±10%	Internal
TX Power	+2 to +7dBm	±3dB	Internal
RX Power	-33 to -9dBm	±3dB	Internal

### ■ Revision History

Revision	Initiated	Reviewed	Approved	DCN	Release Date
Version1.0	yangpeiyun	tangzhiqiang	dinqzheng	New Released.	Aug 18, 2017

### ■ For More Information

#### **ATOP Corporation**

Tel: +86-755-86674946

Fax: +86-755-86296723

Email: [sales@atoptechnology.com](mailto:sales@atoptechnology.com)

Web: [www.atoptechnology.com](http://www.atoptechnology.com)