

## 10.3Gb/s SFP+ Transceiver

### APSP31B33xDL20

#### ■ Product Features

- ✓ Duplex LC connector
- ✓ Hot-pluggable SFP footprint
- ✓ Uncooled 1310nm DFB laser
- ✓ RoHS compliant and Lead Free
- ✓ Distance up to 20Km on 9/125um SMF
- ✓ Metal enclosure for lower EMI
- ✓ Power dissipation <1.0W (0~70°C)  
<1.2W(-40~85°C)
- ✓ Commercial and industrial operating temperature optional
- ✓ SFP MSA SFF-8472 SFF-8431 SFF-8432 Compliant



#### ■ Applications

- ✓ 10GBASE-LR/LW
- ✓ 10G Fibre Channel

#### ■ General

ATOP's APSP31B33xDL20 Small Form Factor Pluggable (SFP+) transceivers are compatible with SFF-8431, SFF-8432 and support 10G Ethernet LR and 10G Fibre Channel. It is designed for use in 10G-Gigabit multi-rate links up to 20km of G.652. Digital diagnostics functions are available via a 2-wire serial interface, as specified in SFF-8472.

#### ■ Product Selection

Part Number	Operating Case temperature	DDMI
APSP31B33CDL20	Commercial(0~70°C)	Yes
APSP31B33IDL20	Industrial(-40~85°C)	Yes

#### ■ Regulatory Compliance

- ESD to the Electrical PINs: compatible with MIL-STD-883 Method 3015



- ESD to the Duplex LC Receptacle: compatible with IEC 61000-4-2
- Immunity compatible with IEC 61000-4-3
- EMI compatible with FCC Part 15 Class B EN55022 Class B (CISPR 22B) VCCI Class B
- Laser Eye Safety compatible with FDA 21CFR 1040.10 and 1040.11 EN60950, EN (IEC) 60825-1,2
- RoHS compliant with RoHS 2 (2011/65/EU)

## ■ Pin Descriptions

Pin	Symbol	Name/Description	Ref.
1	VeeT	Transmitter Ground (Common with Receiver Ground)	1
2	TX Fault	Transmitter Fault. LVTTTL-O	2
3	TX Disable	Transmitter Disable. Laser output disabled on high or open. LVTTTL-I	3
4	SDA	2-Wire Serial Interface Data Line (Same as MOD-DEF2 in INF-8074i). LVTTTL-I/O	2
5	SCL	2-Wire Serial Interface Data Line (Same as MOD-DEF2 in INF-8074i). LVTTTL-I	2
6	Mod_ABS	Module Absent, Connect to VeeT or VeeR in Module.	2
7	RS0	Rate Select 0, optionally controls SFP+ module receiver LVTTTL-I	4
8	LOS	Loss of Signal indication. Logic 0 indicates normal operation. LVTTTL-O	5
9	RS1	Rate Select 1, optionally controls SFP+ module transmitter. LVTTTL-I	4
10	VeeR	Receiver Ground (Common with Transmitter Ground)	1
11	VeeR	Receiver Ground (Common with Transmitter Ground)	1
12	RD-	Receiver Inverted DATA out. AC Coupled. CML-O	
13	RD+	Receiver Non-inverted DATA out. AC Coupled. CML-O	
14	VeeR	Receiver Ground (Common with Transmitter Ground)	1
15	VccR	Receiver Power Supply	6
16	VccT	Transmitter Power Supply	6

17	VeeT	Transmitter Ground (Common with Receiver Ground)	1
18	TD+	Transmitter Non-Inverted DATA in. AC Coupled. CML- I	
19	TD-	Transmitter Inverted DATA in. AC Coupled. CML- I	
20	VeeT	Transmitter Ground (Common with Receiver Ground)	1

**Notes:**

1. Circuit ground is internally isolated from chassis ground.
2. TX Fault is an open collector/drain output .Which should be pulled up with a 4.7K – 10K Ohms resistor on the host board if intended for use. Pull up voltage should be between 2.0V to Vcc+0.3V.A high output indicates a transmitter fault caused by either the tx bias current or the tx output power exceeding the preset alarm thresholds. A low output indicates normal operation .In the low state, the output is pulled to <0.8V.
3. Laser output disabled on TX Disable >2.0V or open, enabled on TX Disable<0.8V.
4. Internally pulled down per SFF-8431 Rev4.1.
5. LOS is open collector output. Should be pulled up with 4.7k – 10kohms on host board to a voltage between 2.0V and 3.6V. Logic 0 indicates normal operation; logic 1 indicates loss of signal.
6. Internally connected

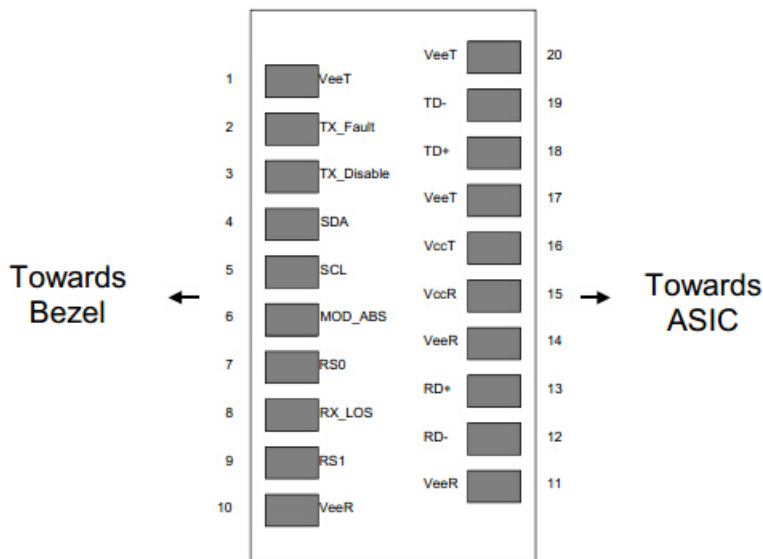

**Pin-out of Connector Block on Host Board**

■ **Recommend Circuit Schematic**

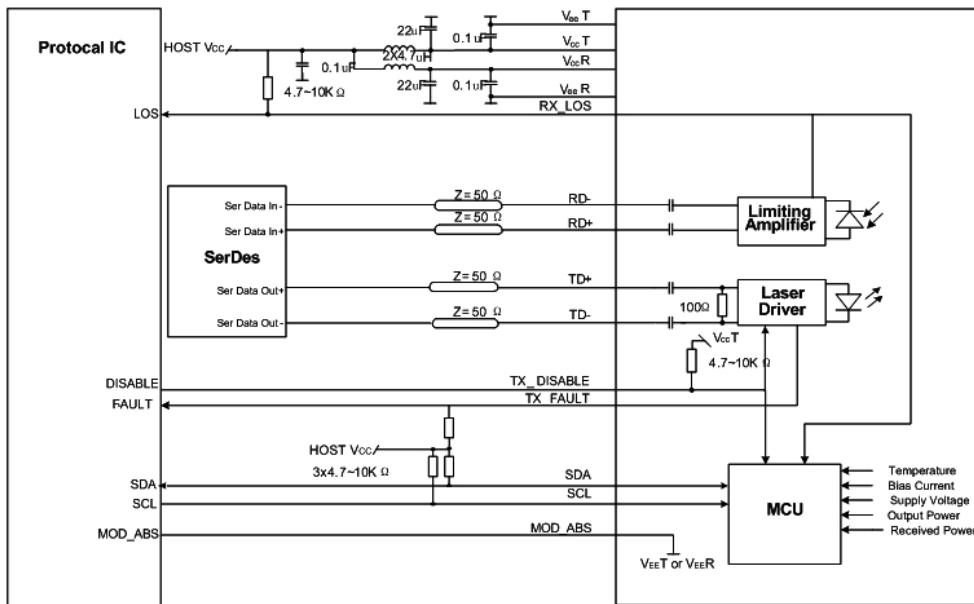

### Absolute Maximum Ratings

Parameter	Symbol	Min	Typ	Max	Unit	Ref.
Maximum Supply Voltage	Vcc	-0.5		+4.0	V	
Storage Temperature	TS	-40		+85	°C	
Operating Humidity	RH	0		85	%	

### Recommended Operating Conditions

Parameter	Symbol	Min	Typ	Max	Unit	Ref.
Power Supply Voltage	Vcc	3.13	3.30	3.47	V	
Power Supply Current	Icc			300	mA	Commercial
	Icc			350	mA	Industrial
Case Operating Temperature	Tc	0		+70	°C	Commercial
	Tl	-40		+85		Industrial
Data Rate(Gigabit Ethernet)	BR		10.3		Gbps	
9/125um G.652 SMF	Lmax			20	km	

### Electrical Characteristics (TOP=25°C, Vcc=3.3Volts)

Parameter	Symbol	Min	Typ	Max	Unit	Ref.
<b>Transmitter</b>						
Input differential impedance	Rin	80	100	120	Ω	1



**APSP31B33xDL20**

Differential data input swing	Vin, pp	120		850	mV	
TX Disable-High		Vcc – 0.8		Vcc	V	
TX Disable-Low		Vee		Vee+ 0.8	V	
TX Fault-High		Vcc-0.8		Vcc	V	
TX Fault-Low		Vee		Vee+0.8	V	
<b>Receiver</b>						
Single ended data output swing	Vout, pp	300		850	mV	2
Data output rise time	Tr	30			ps	3
Data output fall time	Tf	30			ps	3
LOS-High		Vcc – 0.8		Vcc	V	
LOS-Low		Vee		Vee+0.8	V	

**Notes:**

1. AC coupled.
2. Into 100 ohm differential termination.
3. 20 – 80 %

**Optical Characteristics (TOP=25°C, Vcc=3.3 Volts)**

Parameter	Symbol	Min	Typ	Max	Unit	Ref.
<b>Transmitter</b>						
Output Opt. Power	PO	-5		+0.5	dBm	
Optical Wavelength	$\lambda$	1260		1355	nm	
Side-Mode Suppression Ratio	SMSR	30			dB	
Spectral Width(-20dB)	$\Delta\lambda$			1	nm	
Optical Extinction Ratio	ER	3.5			dB	
<b>Receiver</b>						
RX Sensitivity @10.3Gb/s	SENS1			-14.4	dBm	1,2
Receiver Sensitivity (OMA) @ 10.3Gb/s	SENS2			-12.6	dBm	1,2
Receiver Overload		0.5			dBm	
Optical Center Wavelength	$\lambda_C$	1260		1610	nm	
LOS De-Assert	LOSD			-15	dBm	

LOS Assert	LOSA	-30			dBm	
LOS Hysteresis		0.5		5	dB	

**Notes:**

1. Measured with conformance signals defined in FC-PI-2 Rev. 10.0 specifications.
2. Measured with PRBS  $2^{31}-1$  at  $10^{-12}$  BER.

**Mechanical Specifications**

ATOP’s Small Form Factor Pluggable (SFP+) transceivers are compatible with the dimensions defined by the SFP Multi-Sourcing Agreement (MSA), dimensions are in mm.

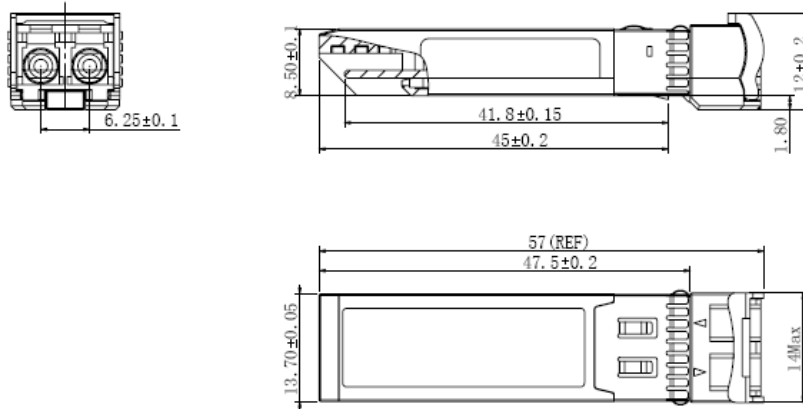

**APSP31B33xDL20**

**EEPROM Information**

EEPROM memory map specific data field description is as below:

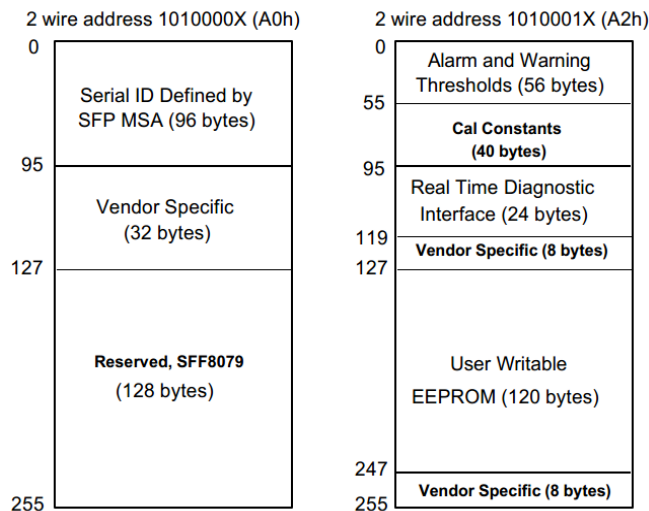



## ■ Digital Diagnostic Monitoring Interface

Five transceiver parameter values are monitored. The following table defines the monitored parameter's accuracy.

Parameter	Range	Accuracy	Calibration
Temperature	0 to +70°C (C)	±3°C	Internal
	-40 to +85°C (I)		
Voltage	2.97 to 3.63V	±3%	Internal
Bias Current	0 to 100mA	±10%	Internal
TX Power	-5 to +0.5dBm	±3dB	Internal
RX Power	-14.4 to 0.5dBm	±3dB	Internal

## ■ Revision History

Revision	Initiated	Reviewed	Approved	DCN	Release Date
Version1.0	yangpeiyun	sunbin	dingzheng	New Released.	July 28, 2016

## ■ For More Information

### ATOP Corporation

Tel: +86-755-86674946

Fax: +86-755-86296723

Email: [sales@atoptechnology.com](mailto:sales@atoptechnology.com)

Web: [www.atoptechnology.com](http://www.atoptechnology.com)