

# Product Specification

Name	Rack Mount Patch Panel	Model	CNOP-999309	Document NO.	SD-D92400-ENG	Version	REV.01
------	------------------------	-------	-------------	--------------	---------------	---------	--------

Max. Fiber Count	
Adapter Type	Cores
SC Simplex	48

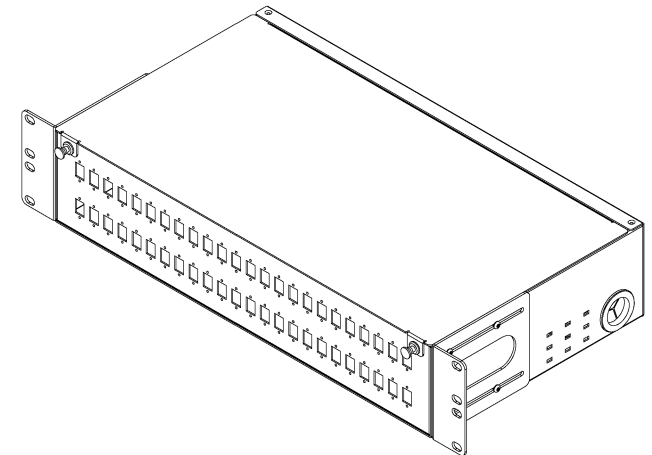
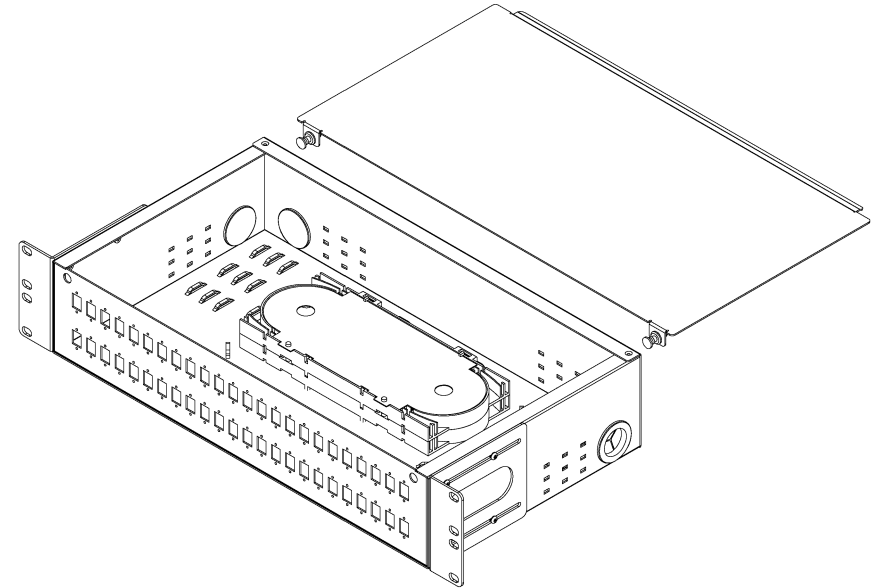
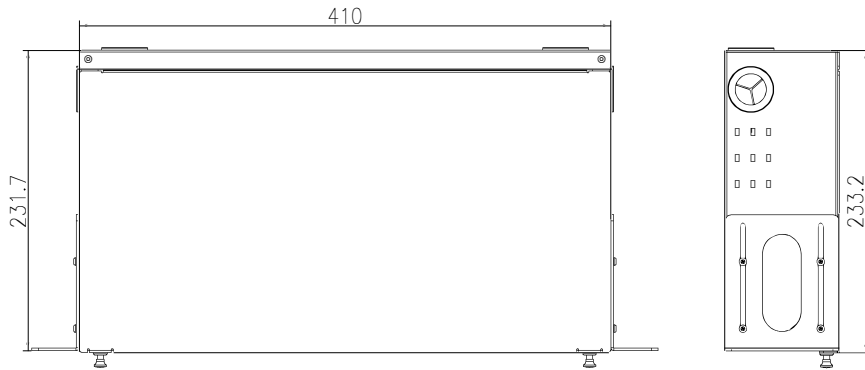
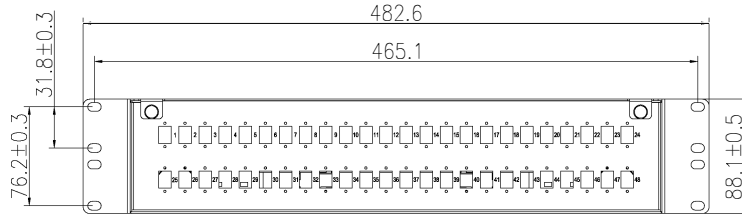

## Product Description:

- 1、Product size (width–depth–height): 482.6mm\*233.2mm\*88.1mm;
- 2、Apply to 19inch rack installation;
- 3、Surface: black powder coating (RAL9005);
- 4、Standard Accessories :
  - 24 Fiber: 1pcs splice tray, 24 pcs fiber protection Heat–shrink sleeve;
  - 48Fiber: 2pcs splice tray, 48pcs fiber protection Heat–shrink sleeve;
- \*5、Adapter and pigtails are optional.