



Product Specification

100Gb/s QSFP28 LR4 Optical Transceiver

Features

- Hot pluggable QSFP28 MSA form factor
- Compliant to IEEE 802.3ba 100GBASE-LR4
- Supports 103.1Gb/s aggregate bit rate
- Up to 20km reach for G.652 SMF
- Single +3.3V power supply
- Operating case temperature: 0~70°C
- Transmitter: cooled 4x25Gb/s LAN WDM DFB TOSA (1295.56, 1300.05, 1304.58, 1309.14nm)
- Receiver: 4x25Gb/s PIN ROSA
- 4x25G electrical interface (OIF CEI-28G-VSR)
- Maximum power consumption 3.5W
- Duplex LC receptacle
- RoHS-6 compliant

Applications

- 100GBASE-LR4 Ethernet Links
- Infiniband QDR DDR and EDR interconnects
- Client-side 100G Telecom connections

1. General Description

100QSFP28-LR4-20-1310 is a 100Gb/s transceiver module designed for optical communication applications compliant to 100GBASE-LR4 of the IEEE 802.3ba standard. The module converts 4 input channels of 25Gb/s electrical data to 4 channels of LAN WDM optical signals and then multiplexes them into a single channel for 100Gb/s optical transmission. Reversely on the receiver side, the module de-multiplexes a 100Gb/s optical input into 4 channels of LAN WDM optical signals and then converts them to 4 output channels of electrical data.

The central wavelengths of the 4 LAN WDM channels are 1295.56, 1300.05, 1304.58 and 1309.14 nm as members of the LAN WDM wavelength grid defined in IEEE 802.3ba. The high performance cooled LAN WDM DFB transmitters and high sensitivity PIN receivers provide superior performance for 100Gigabit Ethernet applications up to 4km links and compliant to optical interface with 100GBASE-LR4 requirements specified in IEEE 802.3ba Clause 88.

100QSFP28-LR4-20-1310 is designed with form factor, optical/electrical connection and digital diagnostic interface according to the QSFP+ Multi-Source Agreement (MSA). It has been designed to meet the harshest external operating conditions including temperature, humidity and EMI



interference.

2. Functional Description

100QSFP28-LR4-20-1310 fmodule receives 4 channels of 25Gb/s electrical data, which are processed by a 4-channel Clock and Data Recovery (CDR) IC that reshapes and reduces the jitter of each electrical signal. Subsequently, DFB laser driver IC converts each one of the 4 channels of electrical signals to an optical signal that is transmitted from one of the 4 cooled DFB lasers which are packaged in the Transmitter Optical Sub-Assembly (TOSA). Each laser launches the optical signal in specific wavelength specified in IEEE 802.3ba 100GBASE-LR4 requirements. These 4-lane optical signals will be optically multiplexed into a single fiber by a 4-to-1 optical WDM MUX. The optical output power of each channel is maintained constant by an automatic power control (APC) circuit. The transmitter output can be turned off by TX_DIS hardware signal and/or 2-wire serial interface.

The receiver receives 4-lane LAN WDM optical signals. The optical signals are de-multiplexed by a 1-to-4 optical DEMUX and each of the resulting 4 channels of optical signals is fed into one of the 4 receivers that are packaged into the Receiver Optical Sub-Assembly (ROSA). Each receiver converts the optical signal to an electrical signal. The regenerated electrical signals are retimed and de-jittered and amplified by the RX portion of the 4-channel CDR. The retimed 4-lane output electrical signals are compliant with IEEE CAUI-4 interface requirements. In addition, each received optical signal is monitored by the DOM section. The monitored value is reported through the 2-wire serial interface. If one or more received optical signal is weaker than the threshold level, RX_LOS hardware alarm will be triggered.

A single +3.3V power supply is required to power up this product. Both power supply pins VccTx and VccRx are internally connected and should be applied concurrently. As per MSA specifications the module offers 7 low speed hardware control pins (including the 2-wire serial interface): ModSelL, SCL, SDA, ResetL, LPMODE, ModPrsL and IntL.

Module Select (ModSelL) is an input pin. When held low by the host, this product responds to 2-wire serial communication commands. The ModSelL allows the use of this product on a single 2-wire interface bus – individual ModSelL lines must be used.

Serial Clock (SCL) and Serial Data (SDA) are required for the 2-wire serial bus communication interface and enable the host to access the QSFP28 memory map.

The ResetL pin enables a complete reset, returning the settings to their default state, when a low level on the ResetL pin is held for longer than the minimum pulse length. During the execution of a reset the host shall disregard all status bits until it indicates a completion of the reset interrupt. The product indicates this by posting an IntL (Interrupt) signal with the Data_Not_Ready bit negated in the memory map. Note that on power up (including hot insertion) the module should post this completion of reset interrupt without requiring a reset.

Low Power Mode (LPMODE) pin is used to set the maximum power consumption for the product in order to protect hosts that are not capable of cooling higher power modules, should such modules be accidentally inserted.

Module Present (ModPrsL) is a signal local to the host board which, in the absence of a product, is normally pulled up to the host Vcc. When the product is inserted into the connector, it completes the



path to ground through a resistor on the host board and asserts the signal. ModPrsL then indicates its present by setting ModPrsL to a "Low" state.

Interrupt (IntL) is an output pin. "Low" indicates a possible operational fault or a status critical to the host system. The host identifies the source of the interrupt using the 2-wire serial interface. The IntL pin is an open collector output and must be pulled to the Host Vcc voltage on the Host board.

3. Transceiver Block Diagram

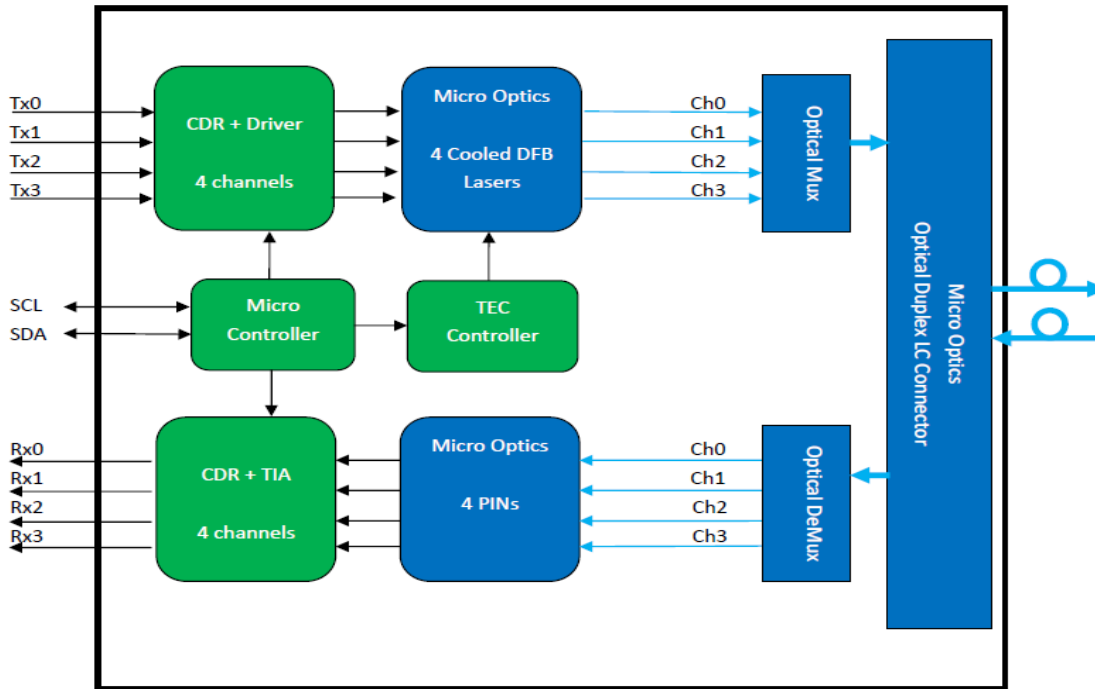

Figure 1. Transceiver Block Diagram

4. Pin Assignment and Description

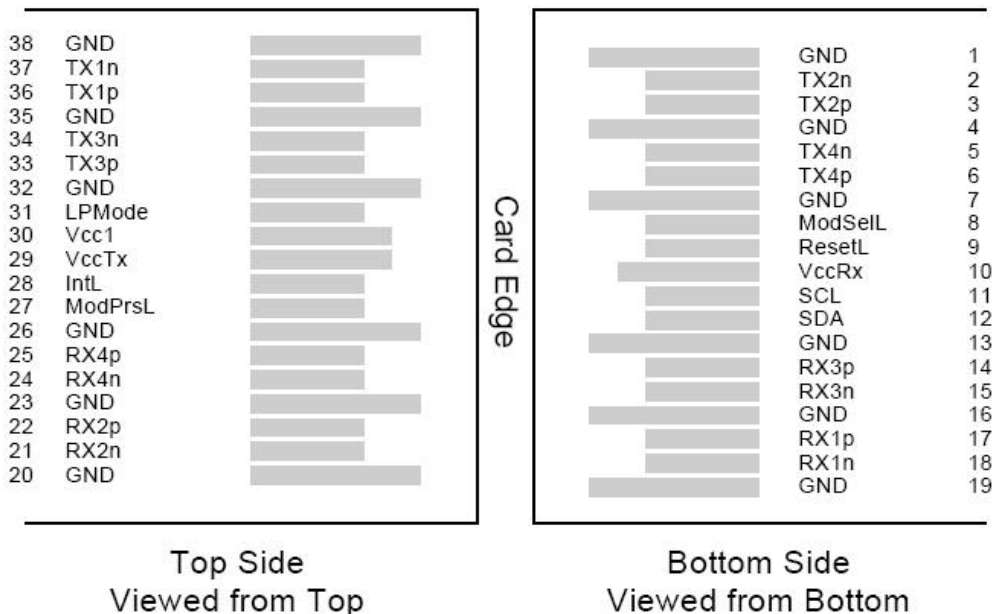



Figure 2. MSA compliant Connector

Pin Definition

| PIN | Logic | Symbol | Name/Description | Notes |
|-----|-------------|---------|--------------------------------------|-------|
| 1 | | GND | Ground | 1 |
| 2 | CML-I | Tx2n | Transmitter Inverted Data Input | |
| 3 | CML-I | Tx2p | Transmitter Non-Inverted Data output | |
| 4 | | GND | Ground | 1 |
| 5 | CML-I | Tx4n | Transmitter Inverted Data Input | |
| 6 | CML-I | Tx4p | Transmitter Non-Inverted Data output | |
| 7 | | GND | Ground | 1 |
| 8 | LVTLL-I | ModSelL | Module Select | |
| 9 | LVTLL-I | ResetL | Module Reset | |
| 10 | | VccRx | +3.3V Power Supply Receiver | 2 |
| 11 | LVC MOS-I/O | SCL | 2-Wire Serial Interface Clock | |
| 12 | LVC MOS-I/O | SDA | 2-Wire Serial Interface Data | |
| 13 | | GND | Ground | |
| 14 | CML-O | Rx3p | Receiver Non-Inverted Data Output | |
| 15 | CML-O | Rx3n | Receiver Inverted Data Output | |
| 16 | | GND | Ground | 1 |
| 17 | CML-O | Rx1p | Receiver Non-Inverted Data Output | |
| 18 | CML-O | Rx1n | Receiver Inverted Data Output | |
| 19 | | GND | Ground | 1 |
| 20 | | GND | Ground | 1 |
| 21 | CML-O | Rx2n | Receiver Inverted Data Output | |
| 22 | CML-O | Rx2p | Receiver Non-Inverted Data Output | |
| 23 | | GND | Ground | 1 |
| 24 | CML-O | Rx4n | Receiver Inverted Data Output | 1 |
| 25 | CML-O | Rx4p | Receiver Non-Inverted Data Output | |
| 26 | | GND | Ground | 1 |
| 27 | LVTTL-O | ModPrsL | Module Present | |
| 28 | LVTTL-O | IntL | Interrupt | |
| 29 | | VccTx | +3.3 V Power Supply transmitter | 2 |
| 30 | | Vcc1 | +3.3 V Power Supply | 2 |
| 31 | LVTTL-I | LPMode | Low Power Mode | |
| 32 | | GND | Ground | 1 |



| | | | | |
|----|-------|------|-------------------------------------|---|
| 33 | CML-I | Tx3p | Transmitter Non-Inverted Data Input | |
| 34 | CML-I | Tx3n | Transmitter Inverted Data Output | |
| 35 | | GND | Ground | 1 |
| 36 | CML-I | Tx1p | Transmitter Non-Inverted Data Input | |
| 37 | CML-I | Tx1n | Transmitter Inverted Data Output | |
| 38 | | GND | Ground | 1 |

Notes:

1. GND is the symbol for signal and supply (power) common for the QSFP28 module. All are common within the module and all module voltages are referenced to this potential unless otherwise noted. Connect these directly to the host board signal common ground plane.
2. VccRx, Vcc1 and VccTx are the receiving and transmission power suppliers and shall be applied concurrently. Recommended host board power supply filtering is shown in Figure 3 below. Vcc Rx, Vcc1 and Vcc Tx may be internally connected within the module in any combination. The connector pins are each rated for a maximum current of 1000mA.

5. Recommended Power Supply Filter

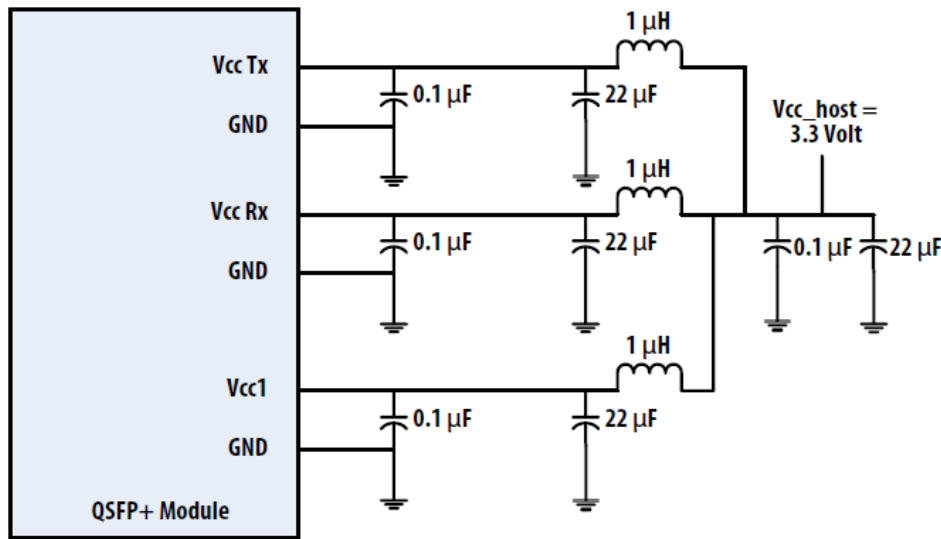

Figure 3. Recommended Power Supply Filter

6. Absolute Maximum Ratings

It has to be noted that the operation in excess of any individual absolute maximum ratings might cause permanent damage to this module.

| Parameter | Symbol | Min | Max | Units | Notes |
|----------------------------|-----------------|------|-----|-------|-------|
| Storage Temperature | T _S | -40 | 85 | degC | |
| Operating Case Temperature | T _{OP} | 0 | 70 | degC | |
| Power Supply Voltage | V _{CC} | -0.5 | 3.6 | V | |



| | | | | | |
|--------------------------------------|-----------------|-----|----|-----|--|
| Relative Humidity (non-condensation) | RH | 0 | 85 | % | |
| Damage Threshold, each Lane | TH _d | 5.5 | | dBm | |

7. Recommended Operating Conditions and Power Supply Requirements

| Parameter | Symbol | Min | Typical | Max | Units |
|----------------------------|-----------------|-------|----------|-----------------|-------|
| Operating Case Temperature | T _{OP} | 0 | | 70 | degC |
| Power Supply Voltage | V _{CC} | 3.135 | 3.3 | 3.465 | V |
| Data Rate, each Lane | | | 25.78125 | | Gb/s |
| Data Rate Accuracy | | -100 | | 100 | ppm |
| Control Input Voltage High | | 2 | | V _{CC} | V |
| Control Input Voltage Low | | 0 | | 0.8 | V |
| Link Distance with G.652 | D | 0.002 | | 4 | km |

8. Electrical Characteristics

The following electrical characteristics are defined over the Recommended Operating Environment unless otherwise specified.

| Parameter | Test Point | Min | Typical | Max | Units | Notes |
|---|-----------------|------|---------|--------------------------------|-------|---------|
| Power Consumption | | | | 3.5 | W | |
| Supply Current | I _{CC} | | | 1.06 | A | |
| Transmitter (each Lane) | | | | | | |
| Overload Differential Voltage pk-pk | TP1a | 900 | | | mV | |
| Common Mode Voltage (V _{cm}) | TP1 | -350 | | 2850 | mV | 1 |
| Differential Termination Resistance Mismatch | TP1 | | | 10 | % | At 1MHz |
| Differential Return Loss (SDD11) | TP1 | | | See CEI-28G-VSR Equation 13-19 | dB | |
| Common Mode to Differential conversion and Differential to Common Mode conversion (SDC11, | TP1 | | | See CEI-28G-VSR Equation 13-20 | dB | |



| | | | | | | |
|--|------|-------------------------------------|--|--------------------------------|----|---------|
| SCD11) | | | | | | |
| Stressed Input Test | TP1a | See CEI-28G-VSR Section 13.3.11.2.1 | | | | |
| Receiver (each Lane) | | | | | | |
| Differential Voltage, pk-pk | TP4 | | | 900 | mV | |
| Common Mode Voltage (Vcm) | TP4 | -350 | | 2850 | mV | 1 |
| Common Mode Noise, RMS | TP4 | | | 17.5 | mV | |
| Differential Termination Resistance Mismatch | TP4 | | | 10 | % | At 1MHz |
| Differential Return Loss (SDD22) | TP4 | | | See CEI-28G-VSR Equation 13-19 | dB | |
| Common Mode to Differential conversion and Differential to Common Mode conversion (SDC22, SCD22) | TP4 | | | See CEI-28G-VSR Equation 13-21 | dB | |
| Common Mode Return Loss (SCC22) | TP4 | | | -2 | dB | 2 |
| Transition Time, 20 to 80% | TP4 | 9.5 | | | ps | |
| Vertical Eye Closure (VEC) | TP4 | | | 5.5 | dB | |
| Eye Width at 10 ⁻¹⁵ probability (EW15) | TP4 | 0.57 | | | UI | |
| Eye Height at 10 ⁻¹⁵ probability (EH15) | TP4 | 228 | | | mV | |

Notes:

1. Vcm is generated by the host. Specification includes effects of ground offset voltage.
2. From 250MHz to 30GHz.



9. Optical Characteristics

| 100G QSFP28 LR4 Lite | | | | | | |
|---|---------------|------------------------------------|---------|---------|-------|-------|
| Parameter | Symbol | Min | Typical | Max | Units | Notes |
| Lane Wavelength | L0 | 1294.5 3 | 1295.56 | 1296.59 | nm | |
| | L1 | 1299.0 2 | 1300.05 | 1301.09 | nm | |
| | L2 | 1303.5 4 | 1304.58 | 1305.63 | nm | |
| | L3 | 1308.0 9 | 1309.14 | 1310.19 | nm | |
| Transmitter | | | | | | |
| Side Mode Suppression Ratio | SMSR | 30 | | | dB | |
| Total Average Launch Power | P_T | | | 10.5 | dBm | |
| Average Launch Power, each Lane | P_{AVG} | -6.0 | | 4.5 | dBm | |
| OMA, each Lane | P_{OMA} | -3.0 | | 4.5 | dBm | 1 |
| Difference in Launch Power between any Two Lanes (OMA) | $P_{tx,diff}$ | | | 5 | dB | |
| Launch Power in OMA minus Transmitter and Dispersion Penalty (TDP), each Lane | | -4.0 | | | dBm | |
| TDP, each Lane | TDP | | | 2.2 | dB | |
| Extinction Ratio | ER | 4 | | | dB | |
| RIN_{20OMA} | RIN | | | -130 | dB/Hz | |
| Optical Return Loss Tolerance | TOL | | | 20 | dB | |
| Transmitter Reflectance | R_T | | | -12 | dB | |
| Average Launch Power OFF Transmitter, each Lane | P_{off} | | | -30 | dBm | |
| Eye Mask{X1, X2, X3, Y1, Y2, Y3} | | {0.25, 0.4, 0.45, 0.25, 0.28, 0.4} | | | | 2 |
| Receiver | | | | | | |
| Damage Threshold, each Lane | TH_d | 5.5 | | | dBm | 3 |
| Total Average Receive Power | | | | 10.5 | dBm | |
| Average Receive Power, each | | -10.6 | | 4.5 | dBm | |



| | | | | | | |
|--|----------------|-----|------|------|-----|---|
| Lane | | | | | | |
| Receive Power (OMA), each Lane | | | | 4.5 | dBm | |
| Receiver Sensitivity (OMA), each Lane | SEN | | | -8.6 | dBm | |
| Stressed Receiver Sensitivity (OMA), each Lane | | | | -6.5 | dBm | 4 |
| Receiver Reflectance | R _R | | | -26 | dB | |
| Difference in Receive Power between any Two Lanes (OMA) | Prx,diff | | | 5.5 | dB | |
| LOS Assert | LOSA | -30 | | | dBm | |
| LOS Deassert | LOSD | | | -13 | dBm | |
| LOS Hysteresis | LOSH | 0.5 | | | dB | |
| Receiver Electrical 3 dB upper Cutoff Frequency, each Lane | F _c | | | 31 | GHz | |
| Conditions of Stress Receiver Sensitivity Test (Note 5) | | | | | | |
| Vertical Eye Closure Penalty, each Lane | | | 1.8 | | dB | |
| Stressed Eye J2 Jitter, each Lane | | | 0.3 | | UI | |
| Stressed Eye J9 Jitter, each Lane | | | 0.47 | | UI | |

Notes:

1. Even if the TDP < 1 dB, the OMA min must exceed the minimum value specified here.
2. Hit ratio 5x10⁻⁵.
3. The receiver shall be able to tolerate, without damage, continuous exposure to a modulated optical input signal having this power level on one lane. The receiver does not have to operate correctly at this input power.
4. Measured with conformance test signal at receiver input for BER = 1x10⁻¹².
5. Vertical eye closure penalty, stressed eye J2 jitter, and stressed eye J9 jitter are test conditions for measuring stressed receiver sensitivity. They are not characteristics of the receiver.



10. Digital Diagnostic Functions

The following digital diagnostic characteristics are defined over the normal operating conditions unless otherwise specified.

| Parameter | Symbol | Min | Max | Units | Notes |
|---|--------------|------|-----|-------|----------------------------------|
| Temperature monitor absolute error | DMI_Temp | -3 | +3 | deg C | Over operating temperature range |
| Supply voltage monitor absolute error | DMI_VCC | -0.1 | 0.1 | V | Over full operating range |
| Channel RX power monitor absolute error | DMI_RX_Ch | -2 | 2 | dB | 1 |
| Channel Bias current monitor | DMI_Ibias_Ch | -10% | 10% | mA | |
| Channel TX power monitor absolute error | DMI_TX_Ch | -2 | 2 | dB | 1 |

Notes:

1. Due to measurement accuracy of different single mode fibers, there could be an additional +/-1 dB fluctuation, or a +/- 3 dB total accuracy.

11. Mechanical Dimensions

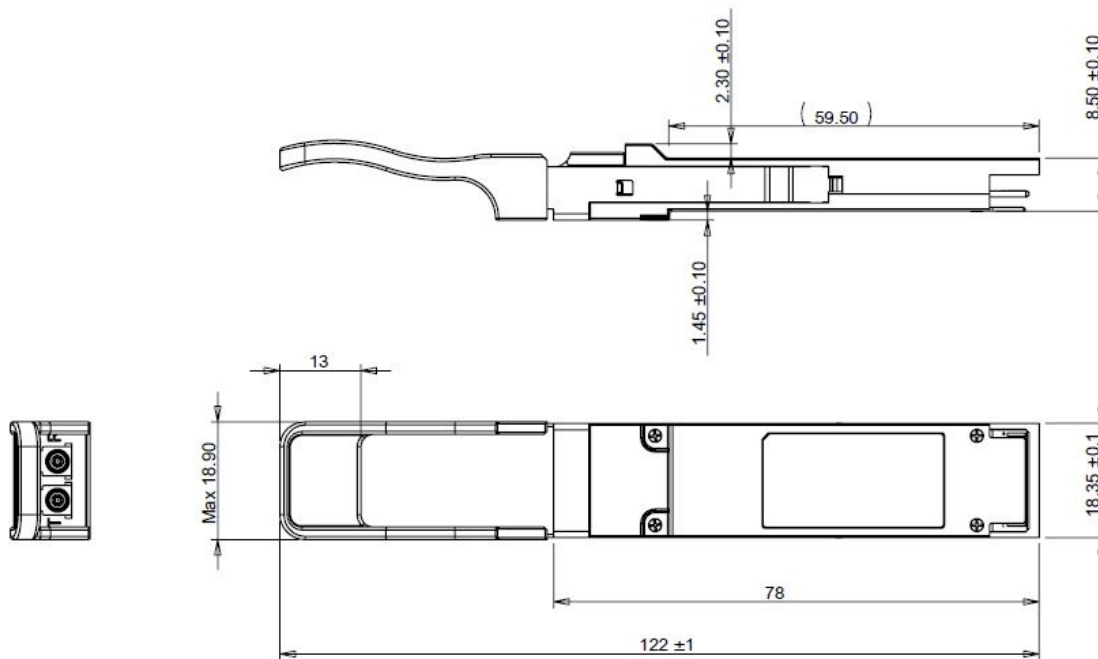

Figure 4. Mechanical Outline



12. ESD

This transceiver is specified as ESD threshold 1KV for high speed data pins and 2KV for all others electrical input pins, tested per MIL-STD-883, Method 3015.4 /JESD22-A114-A (HBM). However, normal ESD precautions are still required during the handling of this module. This transceiver is shipped in ESD protective packaging. It should be removed from the packaging and handled only in an ESD protected environment.

13. Laser Safety

This is a Class 1 Laser Product according to EN 60825-1:2014. This product complies with 21 CFR 1040.10 and 1040.11 except for deviations pursuant to Laser Notice No. 50, dated (June 24, 2007).

Caution: Use of controls or adjustments or performance of procedures other than those specified herein may result in hazardous radiation exposure.