

Elegant PRO 600
IT Rack Cabinet

Elegant IT rack series offers the permanent solution for management of Network devices and cables. The unique, flexible and effective range is the ideal solution to support the Network and server applications with its welded and durable structure.

Elegant IT rack networking Cabinets are intended for installation of data and telecommunication devices and their distribution systems. Mostly used for structured network cabling systems in office environments, Also to be used in computer-rooms and small or large sized data-centers. A lot of options for doors, side- and rear panels, as well as many different accessories, make the use of the enclosure very flexible.

Removable side and rear panels allow comfortable and easy access to the installed devices for maintenance from all sides of the cabinet. For active cooling it is possible to install an optional fan-unit into the roof or 19inch rack mount type fan units. Thanks to flat-pack construction it is possible to bring them also into places with difficult access, basement or attic, In the narrow entrance or stairs.

Vertical mounting rails are adjustable throughout the entire depth of the cabinet and have high carrying capacity with 1.5mm thickness. Silk-screen mounting rails are providing ability to count U-Marking from top to down & down to up for easy device installation.

| | |
|--|-----------------------------------|
| We are responding the needs of users with choice of 9 different height dimensions. | Height : 12U-16U-20U-22U-26U-32U |
| | 36U-42U-45U-47U |
| | Width : 600 mm |
| | Depth : 600 mm & 800 mm & 1000 mm |

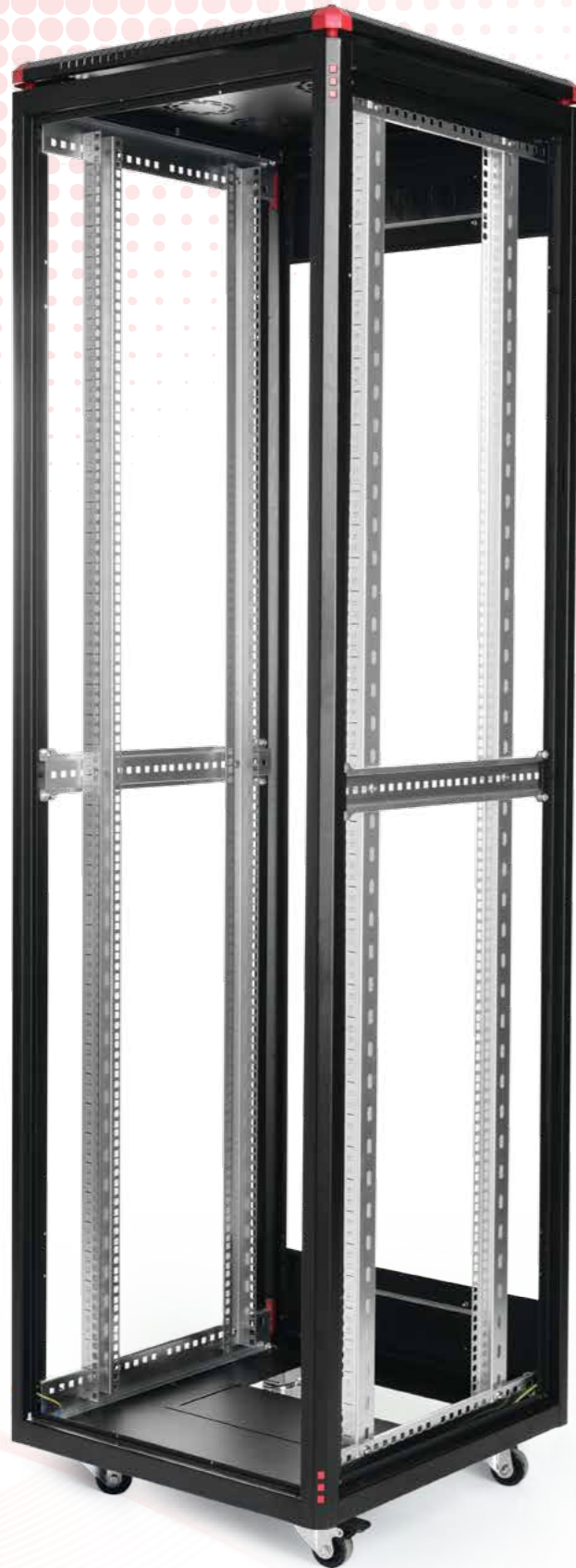

Elegant PRO 600 IT Rack Cabinet

Quick-change fan tray allows accessibility without removing the cables or active devices from the rack in case of any maintenance or replacement needs.

Elegant PRO; The raised top cover has been designed to throw out hot air from the rack and eliminate the risk of dripping water , dust flow , insect entry and also provides a good protection against the unexpected external factors. The ventilation module can be detached by removing 4 pcs screws from the top in case of maintenance or replacement needs.

Protect your device against overheating by choosing the right fan module.

We offer a wide product range of ventilation units with the different fan modules.

On/Off switch Fan modules Analog or digital
Thermostat control unit Fan modules



Rear Cable entry panels with Elegant-Pro

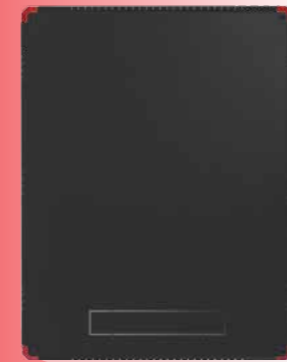

Sliding cable entry panels located on the top cover designed for easy cabling and High-density cabling by using sliding cable entry panels with the dimensions w: 300mm – D: 56 mm



Brushed rear door cable entry panel w: 300mm – D: 56mm dimensions 1 ea Up to 26U and 2pcs on the Highest Elegant-pro Racks.



Sliding cable entry panels located on the bottom plates has been designed for easy cabling and High-density cabling by using sliding cable entry panels with the dimensions w: 300 – D: 125 mm



The vertical mounting rails are adjustable throughout the entire depth of the cabinet and have very high carrying capacity with 1.5mm thickness. Silk-screen mounting rails are providing ability to count U-Marking from top to down & down to up for easy device installation.



Castors

Castor and/or levelling feet could be mounted on to rack.

elegant pro cabinets

Make it easier with multiple cable entries

Elegant PRO 600

IT Rack Cabinet

Door options / W: 600 mm

The front door is designed to provide security with lock mechanism and decorative view together, full-length smoked and shatterproof glass door deployed left & right frames, easily rotated to the left or right

directions by special spring hinge, in case of needs 3 points and single point locking systems are available depends on customer requirements.

Easi removable side panels complete with Barrel lock & Sliding latch locks

RAL 9005-Black (Standard Colour)
RAL 7035-Light Gray (Optional)



elegant pro cabinets

%80 Curved Perforated Metal Door-Single



%63 Curved Perforated Metal Door-Single



Flat Metal Door-Single



Tempered Glass Door-Single



%80 Perforated Metal Door-Double



%63 Perforated Metal Door-Double

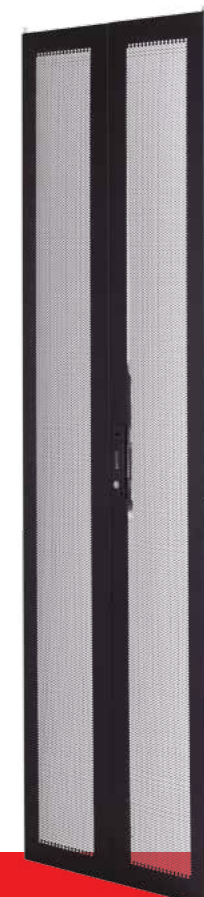

Flat Metal Door-Single



Rear Cable entry panels with
Elegant PRO



Elegant PRO
IT Rack Cabinet



Make it easier with multiple cable entries

Technical Drawing
W: 600 mm d: 600 mm

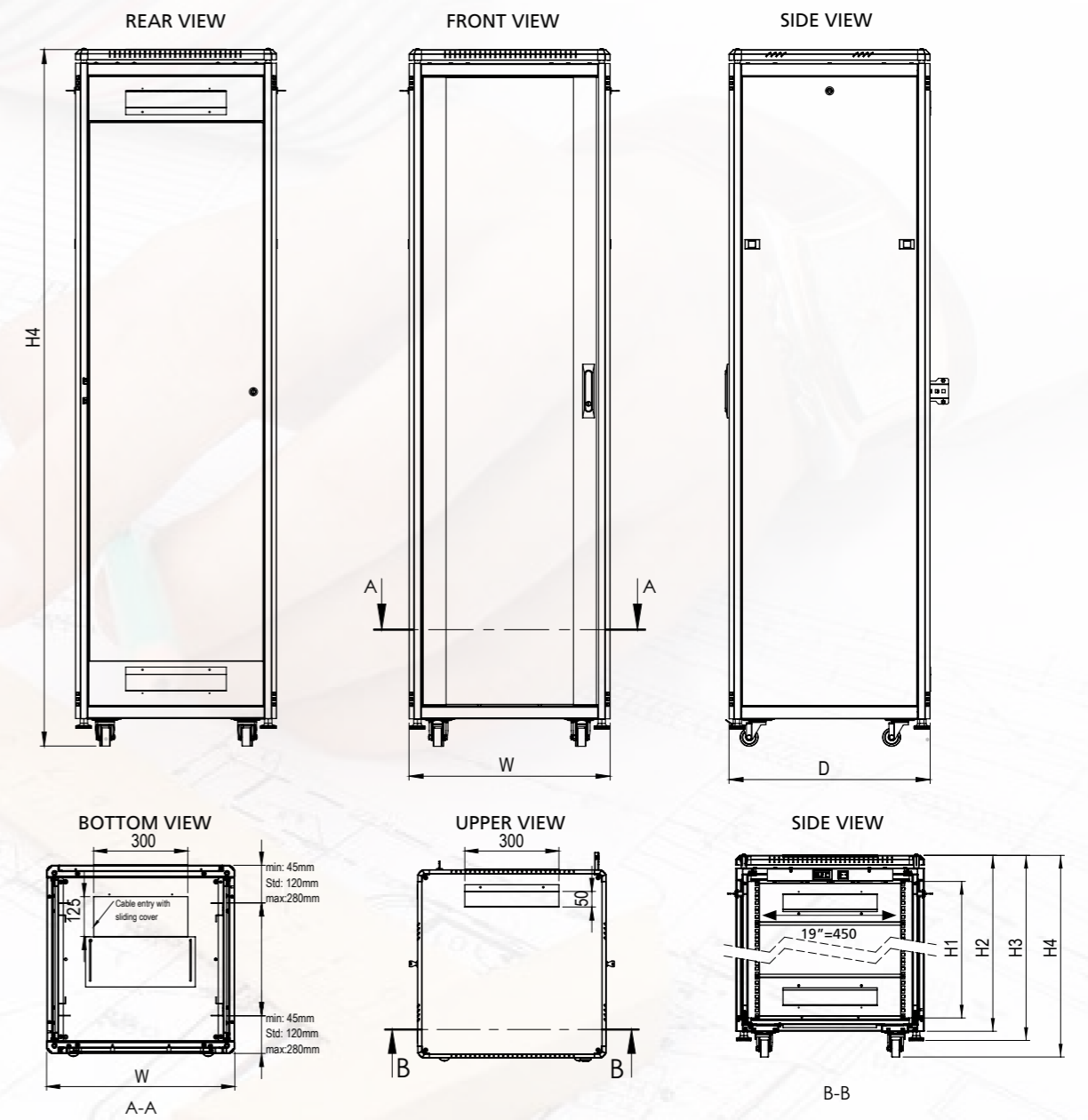
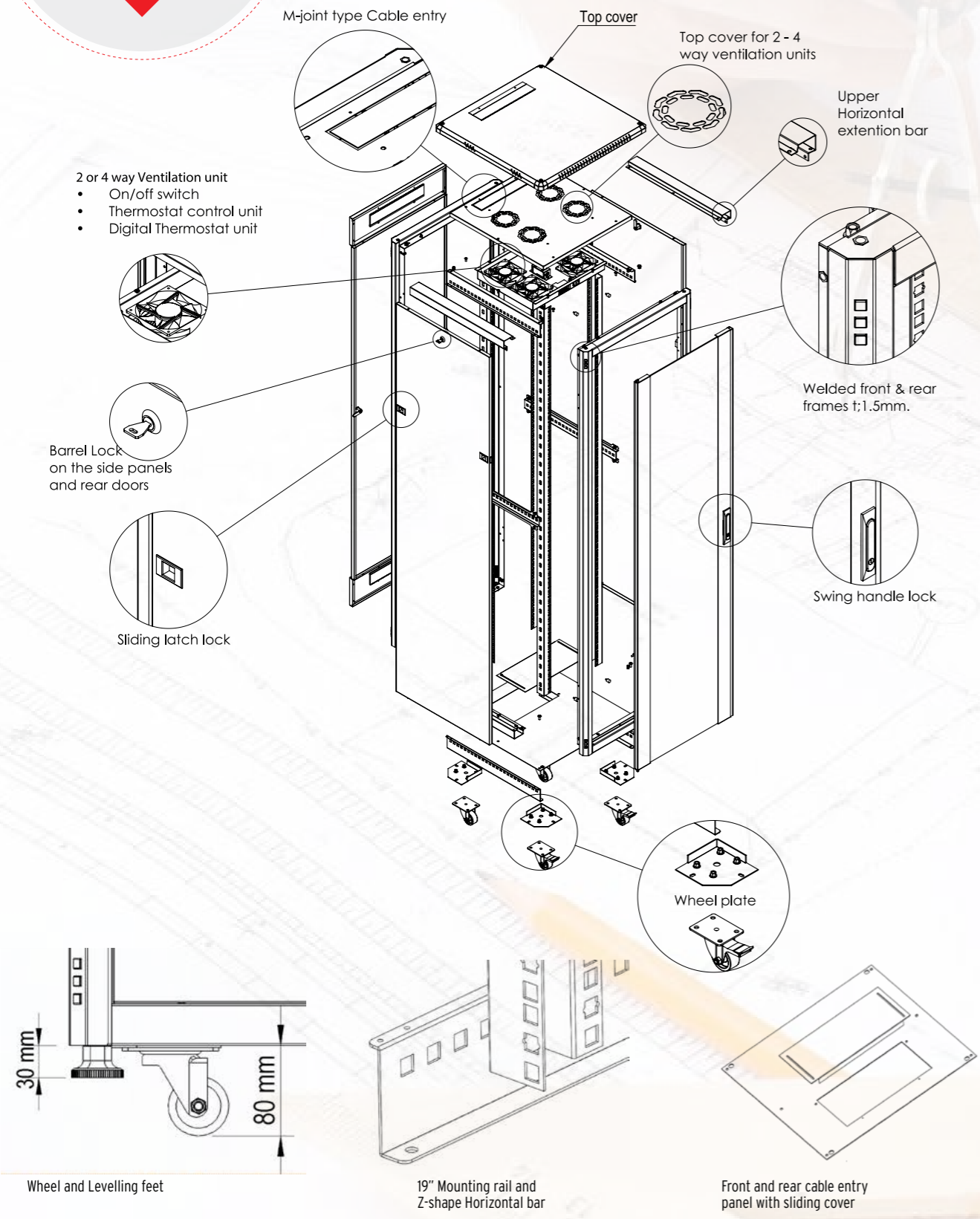

600 x 600 mm FLOOR STANDING ELEGANT PRO RACKS

| Product Code | Product Description | Out Width (W) (mm) | Out Depth (D) (mm) | H:1 Inner Height (mm) | H:2 Out Height without feet & wheel set (mm) | H:3 Out Height with levelling feet (mm) | H:4 Out Height with wheel set (mm) |
|----------------------|---------------------------------------|--------------------|--------------------|-----------------------|--|---|------------------------------------|
| ELGP 12U 6060 CC 111 | Elegant PRO 19" 12U W=600 mm D=600 mm | 600 | 600 | 536,6 | 661,4 | 691,4 | 741,4 |
| ELGP 16U 6060 CC 111 | Elegant PRO 19" 16U W=600 mm D=600 mm | 600 | 600 | 714,4 | 839,2 | 869,2 | 919,2 |
| ELGP 20U 6060 CC 111 | Elegant PRO 19" 20U W=600 mm D=600 mm | 600 | 600 | 892,2 | 1017 | 1047 | 1097 |
| ELGP 22U 6060 CC 111 | Elegant PRO 19" 22U W=600 mm D=600 mm | 600 | 600 | 981,1 | 1107 | 1137 | 1187 |
| ELGP 26U 6060 CC 111 | Elegant PRO 19" 26U W=600 mm D=600 mm | 600 | 600 | 1158,9 | 1284,8 | 1314,8 | 1364,8 |
| ELGP 32U 6060 CC 111 | Elegant PRO 19" 32U W=600 mm D=600 mm | 600 | 600 | 1425,6 | 1551,5 | 1581,5 | 1631,5 |
| ELGP 36U 6060 CC 111 | Elegant PRO 19" 36U W=600 mm D=600 mm | 600 | 600 | 1603,4 | 1729,3 | 1759,3 | 1809,3 |
| ELGP 42U 6060 CC 111 | Elegant PRO 19" 42U W=600 mm D=600 mm | 600 | 600 | 1870,1 | 1996 | 2026 | 2076 |
| ELGP 45U 6060 CC 111 | Elegant PRO 19" 45U W=600 mm D=600 mm | 600 | 600 | 2003,45 | 2129 | 2159 | 2209 |
| ELGP 47U 6060 CC 111 | Elegant PRO 19" 47U W=600 mm D=600 mm | 600 | 600 | 2092,35 | 2218 | 2248 | 2298 |

**CC Means=Color Code, BL=Rail 9005 Black, LG=Rail 7035 Light Gray

Elegant PRO

IT Rack Cabinet

PERFORATED FRONT VIEW



W600
Curved Perforated

PERFORATED REAR VIEW



W600
Splited Perforated

Choice of professionals

GÜNKO

elegant pro kabinler