

<p>EN</p> <p>Cable laying multiple rollers fit for installations of cables with ø 160 mm max. in manholes entrance.</p> <p>Composed by:</p> <ul style="list-style-type: none"> galvanized steel frame n. 3 running rollers made of galvanized steel mounted on shielded ball bearings 	<p>D</p> <p>Schachteilenkbogen zum verlegen von Kabeln bis max. ø 160 mm.</p> <p>Bestehend aus:</p> <ul style="list-style-type: none"> verzinktem Stahlgestell drei Rollen aus verzinktem Stahl, gelagert mittels doppelt geschützter Kugellager 	<p>E</p> <p>Rodillo de tendido de cables para el tendido en curva de cables con ø 160 mm máx.</p> <p>Compuesto por:</p> <ul style="list-style-type: none"> bastidor de acero galvanizado 3 rodillos de deslizamiento en acero cincado montado sobre cojinetes de esferas apantallados 	<p>F</p> <p>Rouleaux pour bords de puits, adapté pour la pose de câbles mesurant jusqu'à ø 160 mm max.</p> <p>Composé de :</p> <ul style="list-style-type: none"> châssis en acier zingué 3 galets en acier galvanisé montés sur roulements à billes blindés 	<p>I</p> <p>Rulliera adatta per la posa di cavi fino al ø 160 mm max. in entrata nei pozzetti.</p> <p>Composto da :</p> <ul style="list-style-type: none"> telaio in acciaio zincato n. 3 rulli di scorrimento in acciaio zincato montati su cuscinetti a sfere schermati
--	---	--	---	--

Accessories • Zubehör • Accesorios • Accessoires • Accessori

<p>[1] Spare roller comes complete of screwed shaft M12, ball-bearings, nuts and bolts.</p>	<p>[1] Ersatzrolle aus verzinktem Stahl, mit Gewindestift M12, Kugellager, Beilagscheiben und Mutter.</p>	<p>[1] Rodillo de repuesto con perno roscado M12, cojinetes, arandelas y bulones.</p>	<p>[1] Galet de rechange muni d'axe fileté M12, roulements, rondelles et boulons.</p>	<p>[1] Rullo di ricambio, completo di perno filettato M12 cuscinetti, rondelle e bulloni.</p>
--	--	--	--	--

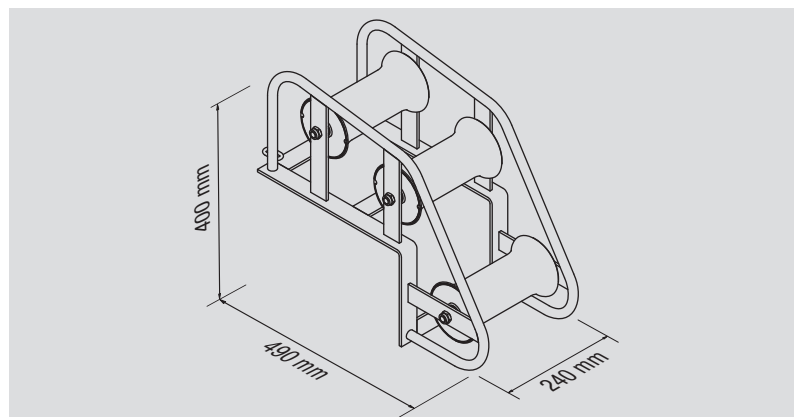
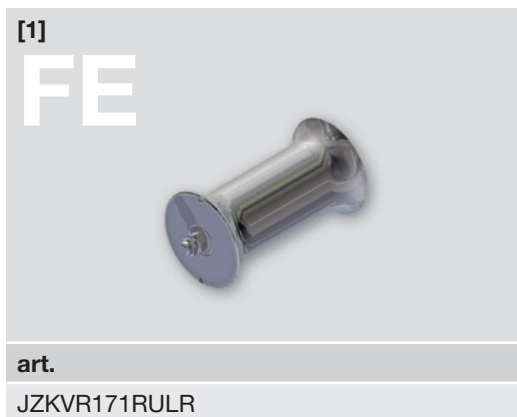

490 x 240 x 400 mm	9 kg	300 daN	ø 160 mm	R 700 mm	ø 76 - 107 x 185 mm