



**PRO-CASE IP55 RATED WALL MOUNTING
CABINET H:07U-26U W:600 x D:450**

- Protection against dangerous sections (IP55)
- Protection against the dust (IP55)
- Protection against the water (IP55)
- Verification Of The Protection Degree For External Mechanical Impacts (IK01)
- With Or Without Fan Usage
- Silk-screened Vertical mounting rails are adjustable throughout the entire depth of the enclosure, t;1.5mm
- *H:Xmm Plinth Units are available for floor type usage*

List Code : PRC XXU 6045 IP55 LG

Technical Data

Dimensions HxWxD in mm H:(Check 2nd page) W:600mm D:450mm
 Height in U 07U–09U–12U–16U–20U-26U
 Color RAL 7035 L.gray color = PRC XXU 6045 IP55 LG

- Standards and Compliances
- ISO9001-2015
 - EN 61587-1
 - EN 62208: 2005-04
 - TS 3033 EN 60529 1997-03
 - CE According the IEC/ISO 17050 – EN 62208:2011 & EN 60335-1
 - IEC/EN 62262:2002 & IEC/EN 60068-2-75:2014 IK10
 - Grounding countinuity maximum 0,1 ohm according to IEC 61010-1 / 6.5.1.3 standards

Mechanical Characteristics

Material Galvanize Sheet Steel
 Inside height in mm 668,50
 Outside height in mm (Check 2nd page for different height options)
 Load Carrying Capacity 200kg / 440,90lbs
 IP rating IP55

We are responding the needs of users with choice of 6 different height dimensions.

Height : 07U–09U–12U–16U–20U-26U
 Width : 600mm
 Depth : 450mm

Technical Drawings

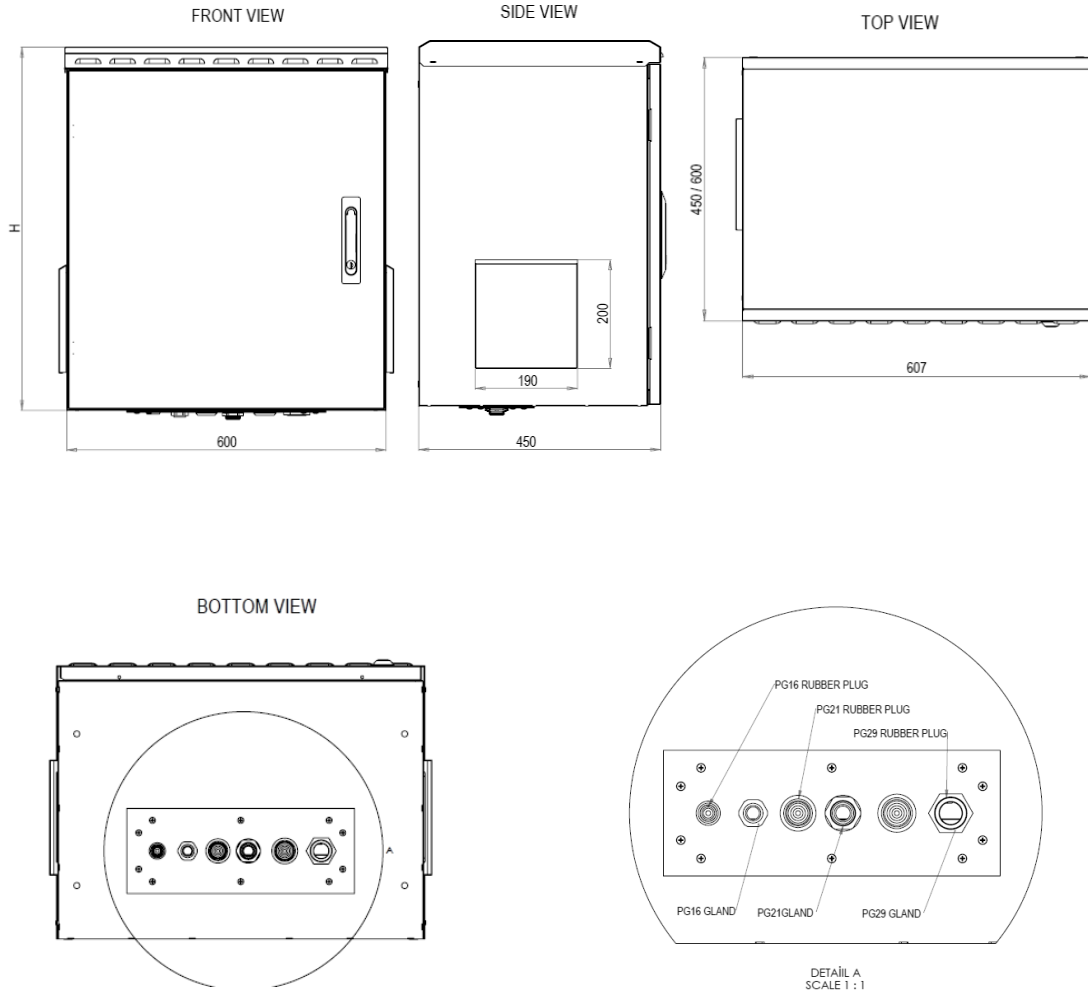

Product code	Product description	Out width (W)	Out depth (D)	Out height (H)
PRC 07U 6045 IP55 LG	19" PRO-Case 07U 600x450 IP55 Cabinet	600	450	450
PRC 09U 6045 IP55 LG	19" PRO-Case 09U 600x450 IP55 Cabinet	600	450	540
PRC 12U 6045 IP55 LG	19" PRO-Case 12U 600x450 IP55 Cabinet	600	450	670
PRC 16U 6045 IP55 LG	19" PRO-Case 16U 600x450 IP55 Cabinet	600	450	850
PRC 20U 6045 IP55 LG	19" PRO-Case 20U 600x450 IP55 Cabinet	600	450	1025
PRC 26U 6045 IP55 LG	19" PRO-Case 26U 600x450 IP55 Cabinet	600	450	1295

4 DIFFERENT FIXING METHODS

Please order one of the fixing bracket separately if needed.

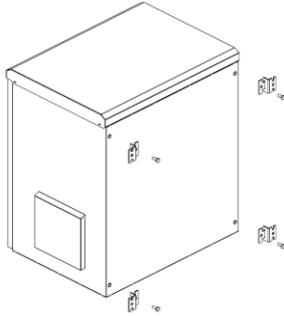

With Wall-mounting brackets

Product Code : PRC DVMA 01

1

Wall mounting brackets has been designed for hanging enclosure to the wall, Bracket thickness is 3mm and provides load carrying capacity up to 200kg.



3mm thickness

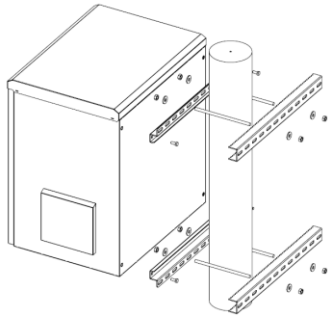

Universal Pole-mounting brackets

Product Code : PRC DRMA 01

2

Pole modules ; Universal type pole module provides ease of use in order to clamping wood or metal poles, it is providing extremely strong clamping on the any height/type poles without need the information of pole dimension or diameter.

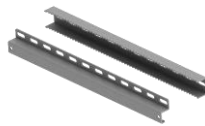

3mm thickness

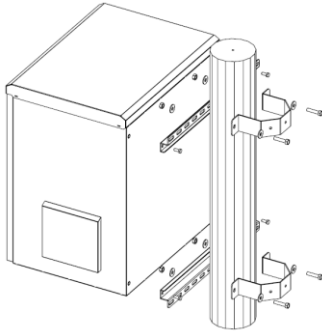

Fixing Bracket For Multi-edge type of poles

Product Code : PRC MEMA 01

3

Multi-edged type wall mounting brackets has been designed for hanging enclosure to the wall, Bracket thickness is 3mm

Poles dimension / diameter / angles must be provided by the customer.

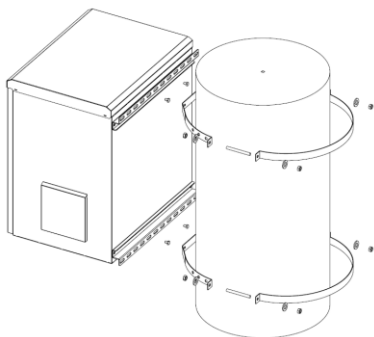

Stainless steel strip For Round type poles

Product Code : PRC RTMA 01

4

Round type stainless steel wall mounting brackets has been designed for hanging enclosure to the wall, Bracket thickness is 2mm

Poles dimension / diameter / angles must be provided by the customer.

TECHNICAL SPECIFICATIONS

Please order insulation material separately if needed.

Polythene insulation details / Double Wall

It consist of 3 different materials

- 1st. Main Enclosure Body
- 2nd. Polythene insulation material
- 3rd. Galvanize inner wall

These components are provides high resistance against the climatic changes with support of Fan & filter combination to control internal temperatures inside the enclosure, it is the cost-effective way to eliminate problems that may occur from internal and environmental overheating factors.

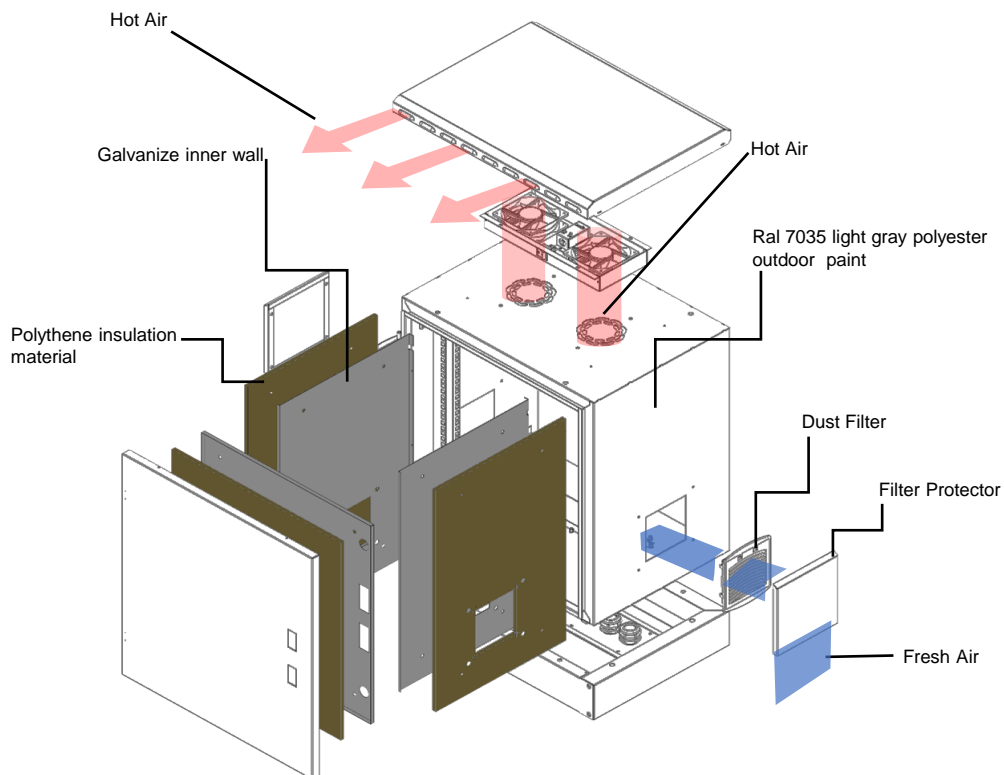

PRC IZ 07U 6045 PE10	07U 600x450mm isolation module / Galvanize inner wall & isolation material
PRC IZ 09U 6045 PE10	09U 600x450mm isolation module / Galvanize inner wall & isolation material
PRC IZ 12U 6045 PE10	12U 600x450mm isolation module / Galvanize inner wall & isolation material
PRC IZ 16U 6045 PE10	16U 600x450mm isolation module / Galvanize inner wall & isolation material
PRC IZ 20U 6045 PE10	20U 600x450mm isolation module / Galvanize inner wall & isolation material
PRC IZ 26U 6045 PE10	26U 600x450mm isolation module / Galvanize inner wall & isolation material

VENTILATION OPTIONS

STANDARDS : EMC EN55032:2015 & LVD IEC 62368-1 :2018

Power Characteristics

Voltage range	220/240
Freq Hz	50/60
Current (A)	0,14A
Power W	22
Speed RPM	2700/3000
Noise level in (dB)	40/47dB
Air flow M3/Hr & CFM	133/162 & 82/95

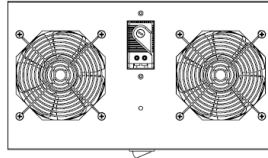

Compatible Fan Units

PRC FN 01	Procace Ventilation unit with 1 Fan+with On/Off switch control
PRC FN 02	Procace Ventilation unit with 2 Fans+with On/Off switch control
PRC FN T1	Procace Ventilation unit with 1 Fan+Analog Thermostat
PRC FN T2	Procace Ventilation unit with 2 Fans+Analog Thermostat
PRC FN DT1	Procace Ventilation unit with 1 Fan+Digital Thermostat
PRC FN DT2	Procace Ventilation unit with 2 Fans+Digital Thermostat

Note: compatible with all 19inch rack mount 2 way Fan units

SHALVES

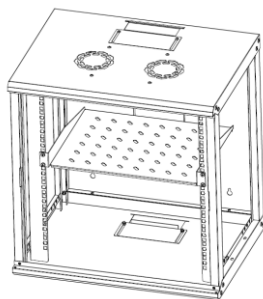

Example Shelf Picture

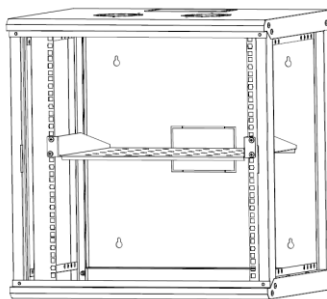

Example Shelf Picture

MODEM SHELVES LOAD CARRYING CAPACITIES

- Fixed shelf : 50kg / 110lbs

Depth 450mm Wall mounting cabinets are compatible with only front fixing type Cantilever shelves !

Compatible Shelves

PA CC RK MR 1U 20	1U 19" D=200 mm Cantilever Shelf
PA CC RK MR 1U 25	1U 19" D=250 mm Cantilever Shelf
PA CC RK MR 1U 35	1U 19" D=350 mm Cantilever Shelf
PA CC RK MR 2U 30	2U 19" D=300 mm Cantilever Shelf

PLINTH UNIT FOR FLOOR TYPE USAGE

Plinth must be order separately for floor usage

The plinth has been developed to simplify installation of outdoor enclosures on the concrete floors, also eliminate risk of the rain & flood in a certain rate, it is also possible to make a great cable storage depending on the base height.

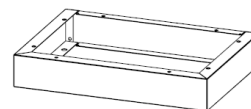
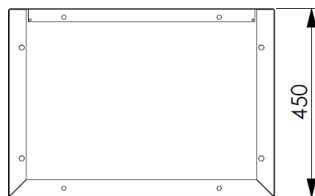
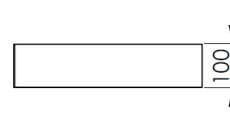
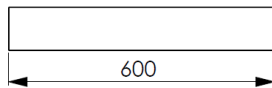

PRC BZ 6045 H10	Plinth 600X450mm H:100mm
PRC BZ 6045 H20	Plinth 600X450mm H:200mm
PRC BZ 6045 H30	Plinth 600X450mm H:300mm
PRC BZ 6045 H40	Plinth 600X450mm H:400mm

IP55 ENCLOSURE MECHANICAL INSPECTION AND RESULTS

1) PROTECTION AGAINST DANGEROUS SECTIONS (IP55)

TS 3033 EN 60529 / MARCH 1997 + A1 2005 Article: Diameter 1.0mm as specified in 12.2

experiment wire with length 100mm, When pressed against the housing with a force of 1N + 10% and attempted to insert it through any opening of the housing, test wire did not come into contact with dangerous voltage sections. protection qualified with standard.

2) PROTECTION AGAINST THE DUST (IP55)

TS 3033 EN 60529 / MARCH 1997 + A1 2005 Article: After waiting for 8 hours in a dust cabinet in accordance with 13.4 and 13.5 (category 2 without vacuum pump), In the visual inspection, no dust entry into the sample was observed.

3) PROTECTION AGAINST THE WATER (IP55)

TS 3033 EN 60529 / MARCH 1997 + A1 2005 Article: 14.2.5. Exposed to gushing water for 3 minutes

and at the end of the experiment, it was observed that there was no amount of superficial water leakage over the insulating sections along the length of the surface leak points that would impair the safety of the equipment which would adversely affect the failure of the equipment.

4) VERIFICATION OF THE PROTECTION DEGREE FOR EXTERNAL MECHANICAL IMPACTS (IK01)

As described in Article: 9.6 , the sample has been tested with an impact hammer with 0.14 Joule impact energy on the outer surface and each surface which is in a uniform manner surface has not exceed the IP code and dielectric strength based on standard of EN 62208 / April 2005

CLIMATIC TESTS (Performance level C2)

For the climatic tests only the sample enclosure were chosen as the representative samples regarding the material used for the structure of the Mechanical structures for electronic equipment.

Cold (IEC 60068-2-1:Ab; 1993)

- Ambient temperature: +23°C,
- Temperature of the exposure: -25°C +/-3°C,
- Duration of the exposure (after the temperature stability was reached): 16 hours

Dry heat (IEC 60068-2-2:Bb; 1974)

- Ambient temperature: +23°C,
- Temperature of the exposure: +70°C +/-2°C,
- Duration of the exposure (after the temperature stability was reached): 16 hours

Damp heat cyclic (IEC 60068-2-30:Db;Variant 2; 1980)

- The temperature was increased from +25°C to +55°C; Rel. hum. was not less than 95% r.h.
- Temperature setting time (25+55°C): 3 hours
- The temperature was maintained at +55°C +/-2°C and relative humidity 93+/-3% r.h.
- Duration of the exposure at +55°C: 9 hours
- The temperature was decreased from +55°C to +25°C; Rel. hum. was not less than 95% r.h.
- Temperature setting time (55+25°C): 3 hours
- The temperature was maintained at +25°C +/-3°C ; Rel. hum. was not less than 95% r.h.
- Duration of the exposure at +25°C: 9 hours
- Duration of one cycle: 24 hours
- The number of cycles: 2

Visual examination of the sample shows no significant change, modification or decrease after the climatic tests.

5 INDUSTRIAL ATMOSPHERE (Performance level A3)

For the climatic tests only the samples IP55 enclosure were chosen as the representative samples regarding the material used for the structure of the Mechanical structures for electronic equipment.

The test conditions for the industrial atmosphere tests are given in Sections 5.1 and 5.2.

Salt mist test (IEC 60068-2-11:Ka;1981)

- Metal parts of the housing holder, grounding cable with connector, screws, nuts, washers, lock and keys were placed into the spray chamber (Figures 6 and 7)
- Temperature in the chamber was maintained: 35 0C +/-2 0C,
- Saline solution: 5 parts of the NaCl and 95 parts of the distilled water,
- Intensity of the spray: Horizontal collecting surface of the chamber: 7854 cm2, Volume of the solution gathered per hour: 264 ml/h, (Required volume per hour: 98±295ml/h),
- Density of the solution at 350C: 1031 kg/m3,
- pH of the solution at 35 0C: 6.7,
- Duration of the test: 4 days

Figure

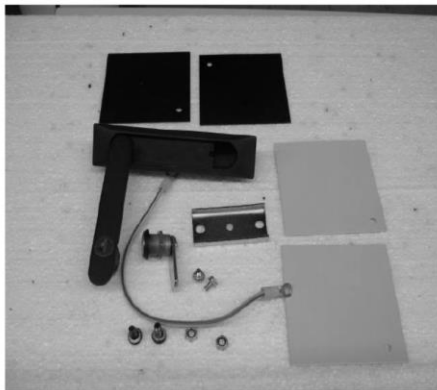

Figure 6

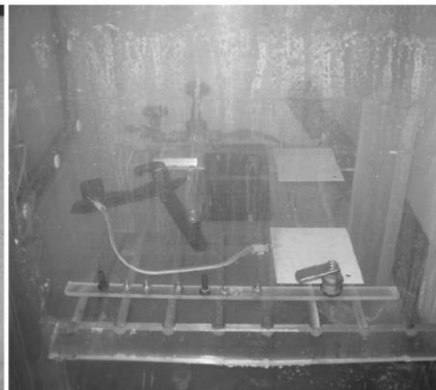

Figure 7

After the test was completed the samples were washed and plunged into running water, then rinsed in distilled water and dried in free air.

The visual examination of the samples after the test shows slight traces of corrosion on the assembling material, on the housing parts there were no visual traces of deterioration (material changes, oxidation, etc.).